

**Recitals**

- a. The Consumer described in the attached Schedule hereto has applied for an electricity connection to  
[e.g.] **Ceylon Electricity Board** (the "Licensee"), a body corporate established by Ceylon Electricity Board Act, No. 17 of 1969 and having its head office at 50, Sir Chittampalam A. Gardiner Mawatha, Colombo 2, Sri Lanka,
- 
- [e.g.] **Lanka Electricity Company (Private) Limited** (the "Licensee"), a Company incorporated under Companies Act, No. 07 of 2007 and having its head office at No. 411, E.H. Cooray Building, Galle Road, Colombo 3, Sri Lanka;
- b. The Consumer has requested the Licensee to supply electrical energy for the purpose identified and at the premise of the Consumer situated at the address given in the Schedule hereto, and the Licensee has agreed to supply the same subject to the terms and conditions of this Agreement.
- c. The Consumer has also requested for and the Licensee has agreed to provide the facilities as provided in the Addendum, if so applicable.
- d. The Licensee holds the Electricity Supply and Distribution Licence No. [insert] issued by the Public Utilities Commission of Sri Lanka in terms of Sri Lanka Electricity Act, No. 20 of 2009.

NOW, THEREFORE, in consideration of the premises and considerations set forth herein, the Parties agree as follows:

**1. Definitions and Interpretation**

- 1.1 In this Agreement (including the recitals above), unless the context otherwise requires, the words, phrases and expressions set out in this Section shall have the meanings given to them in this section.

**Act** means an Act of Parliament, including any statutory provision, which amends or replaces it;

**Addendum** means an addendum attached to this Agreement and the provisions and conditions contained in these addenda shall have the same effect as if set out in the body of this Agreement;

**Agreement** means this agreement made in terms of the Section 25 (7) (d) of the Sri Lanka Electricity Act, No. 20 of 2009;

**Annex** means an annex attached to an Addendum, and the provisions and conditions contained in those Annexes shall have the same effect as if set out in the body of this Agreement;

**Commission** means the Public Utilities Commission of Sri Lanka, established under Public Utilities Commission of Sri Lanka Act, No. 35 of 2002;

**Consumer** means the person whose particulars are furnished in the Schedule hereto;

**Consumer Rights and Obligations** means the statement published by the Commission (as amended) pursuant to Section 3(1)(e) of the Sri Lanka Electricity Act, No. 20 of 2009;

**Contract Demand** means the maximum demand for electricity (expressed in Amperes or kVA, as the case may be) at the Premises as stated in the Schedule;

**Domestic Use** means use of electricity for domestic purposes in private residences;

**General Use** means use of electricity in shops, offices, banks, warehouses, public buildings, hospitals, educational establishments, places of entertainment and other premises not covered under any other use;

**Government Use** means use of electricity in schools, hospitals, vocational training institutions, and universities, which are fully owned by the Government of Sri Lanka and funded through the national budget and provide their services free of charge to the general public;

**Hotel Use** means use of electricity in hotels approved by the Sri Lanka Tourism Development Authority;

**Industrial Use** means use of electricity for Agriculture, Forestry and Fishing, Mining and Quarrying, Manufacturing, Electricity; Gas; Steam and Air Conditioning Supply, Water Supply; Sewerage, Waste Management and Remediation Activities as classified under Gazette Extraordinary No. 1904/58 of 6<sup>th</sup> March, 2015;

**Parties** means the parties to this Agreement. In the case of juristic persons, it includes their permitted heirs, successors, executors and administrators;

**Premises** means the land, building or the structure to which the electricity connection is made, as described in the Schedule;

**Regulation** means a regulation duly made under Sri Lanka Electricity Act, No. 20 of 2009;

**Religious Use** means use of electricity in:

- i. places of public religious worship including private residences of priests where such residences are associated with or are within the place of public religious worship,
- or
- ii. homes for aged, orphanages and homes for the handicapped, which are specifically certified by the Director of Social Services as charitable institutions, and the premise should not include any building used for commercial purposes;

**The Schedule** means the Schedule attached to this Agreement and the provisions and conditions contained in the Schedule shall have the same effect as if set out in the body of this Agreement; and,

**Supply Services Code** means the code published by the Licensee (as amended) pursuant to Section 18 (b) of Sri Lanka Electricity Act, No. 20 of 2009.

- 1.2 Words importing natural persons shall include firms, corporations and bodies corporate.
- 1.3 Words importing the masculine gender shall include the feminine gender.
- 1.4 Words importing the singular number shall include the plural number and vice versa, where the context requires.

## **2. Duration of the Agreement**

Subject to the provisions of effectiveness of Addenda, if any, hereto, this Agreement shall commence from the date hereof and shall continue to be in force until it is terminated in accordance with the provisions of this Agreement.

## **3. Consumer Rights and Obligations, Supply Services Code of the Licensee**

The Consumer hereby acknowledges receipt of current copies of the Consumer Rights and Obligations and Supply Service Code. The Consumer is expected to be familiar with the requirements stipulated therein.

The Licensee reserves the right to revise the Supply Service Code from time to time, with due approvals from the Commission. Such revisions would be notified to consumers by public notices.

## **4. Limitations for supply and use of electricity**

- 4.1 The type and limitations of the electricity supply connection that is made available to the Consumer are more fully specified in the Schedule. If there is any change to or intent to change those specifications, the Consumer shall forthwith inform the Licensee of such change, in order to make the requisite amendments to the Schedule. The charges applicable to such changes, if any, would be as approved by the Commission from time to time.
- 4.2 The Consumer, while using electricity under this Agreement, shall not deviate from any parameter or exceed any limit specified in the Schedule.
- 4.3 Subject to the applicable law, the Licensee shall not deviate from any parameter or exceed any limit specified in the Schedule.

- 4.4 The Licensee, at its sole discretion, may interrupt or temporarily disconnect the Consumer's electricity supply at any time, with due notices prescribed by the Supply Service Code:
- i. due to circumstances beyond the control of the Licensee;
  - ii. if the Licensee needs to carry out work or testing on its distribution system; or
  - iii. due to emergencies, in order to protect life, property or equipment.

## **5. Licensee's Equipment**

- 5.1 All electrical wiring, metering equipment, apparatus or works beyond the metering point (as indicated in the Schedule) are owned and maintained by the Licensee.
- 5.2 The Licensee shall be responsible for keeping all wiring, apparatus or works (excluding those owned by the Consumer) located in the Premises, which are used for or in connection with the supply or use of electricity in safe and good working order.
- 5.3 Consumer shall permit the Licensee to install and keep installed an electric line and/or electrical plant required for the purpose of providing the supply of electricity to his Premises; on, under or over the Premises
- 5.4 Consumer shall take proper care of the Licensee's equipment installed on his/her Premises and to inform forthwith the Licensee of any defect or occurrence that has (or suspected to have) resulted in any damage to the Licensee's equipment.
- 5.5 If Licensee's equipment located in the Consumer's Premises are lost or damaged due to fire or any other cause at the Premises, occasioned by the Consumer or his agents, the Consumer shall be responsible to defraying of the costs of replacement of such lost or damaged equipment of the Licensee.
- 5.6 Subject to the provisions of the Sri Lanka Electricity Act, No. 20 of 2009, the Consumer shall permit entry to the Premises by the representatives of the Licensee.

## **6. Consumers' Installation**

- 6.1 The Consumer shall be responsible for keeping all electrical wiring, apparatus or works (excluding those owned by the Licensee) located in the Premises, which are used for or in connection with the supply or use of electricity in safe and good working order. The Consumer shall be responsible for installing and maintaining the requisite protective devices for electrical appliances that are used in the Premises.
- 6.2 In the case of three-phase connections, subject to practical tolerances, the Consumer shall have his total electrical load equally distributed over the three phases.
- 6.3 The Consumer shall not use electricity in any manner which interferes with Licensee's electricity supply or supply to or use of electricity in any other premises, in contravention of the applicable laws.
- 6.4 The Consumer shall ensure all the time that any other source of electrical energy used by the Consumer does not operate in parallel with the Licensee's network.
- 6.5 If the Consumer wishes to claim compensation in the event his appliances, equipment or property is damaged due to abnormal voltages or phase reversals caused by the Licensee's network, the relevant provisions of the Electricity (Distribution) Performance Standards Regulations must apply.
- 6.6 The Consumer shall obtain a safety clearance certificate from the Licensee before erecting any new building or structure within the Premises, in terms of the Electricity (Safety, Quality and Continuity) Regulations.
- 6.7 The Consumer shall ensure that no tree or building within the Premises to come so close to any overhead line as to cause danger. In the event that it is required by the Consumer to fell or lop or cut back its roots when a tree is or will be in such close proximity to an electric line or electrical plant, which has been installed or is being installed or is to be installed by the Licensee, as to:
- (a) obstruct or interfere with the installation, maintenance or working of the line or plant; or

(b) constitute an unacceptable source of danger to public.

The provisions of the relevant guidelines made by the Commission and Supply Service Code shall apply in these instances.

## **7. Metering**

- 7.1 For the purpose of registering the quantity of electricity consumed by the Consumer under this Agreement, a suitable meter and metering equipment shall be provided by the Licensee. However, subject to provisions of the Sri Lanka Electricity Act, No. 20 of 2009 and the guidelines made thereto by the Commission, the Licensee is entitled to estimate the consumption by the Consumer and recover charges accordingly.
- 7.2 The Consumer shall take proper care of the Licensee's metering equipment installed on his/her Premises and to inform forthwith the Licensee of any occurrence that has (or suspected to have) resulted in any damage to the Licensee's metering equipment.
- 7.3 The Consumer at any time may request the Licensee to test the accuracy of the Licensee's metering equipment installed at the Premises by paying a meter testing fee approved by the Commission. If the meter is found to be working outside the accuracy limit as specified in the Supply Service Code, it shall be replaced at the Licensee's cost and the testing fee paid by the Consumer will be refunded. If it is so warranted in such instances, the Consumer's electricity account would be retrospectively adjusted to reflect the correction. The detailed requirements related to meter testing and adjustments of the account are more fully described in the Supply Services Code.
- 7.4 The Licensee may undertake inspection and testing of Licensee's metering equipment installed at the Premises from time to time. Subject to the provisions of the Sri Lanka Electricity Act, No. 20 of 2009, the Consumer shall permit entry to the Premises by the representatives of the Licensee for these purposes.
- 7.5 The Parties acknowledge that every person, including the Consumer, who intentionally or negligently:-
- i. Alters, or abets altering, the quantity of electricity registered in any meter; or
  - ii. Prevents, or abets preventing, any meter from registering the quantity of electricity passing through that meter

is liable for punishment under Sri Lanka Electricity Act, No. 20 of 2009.

## **8. Tariff and Billing**

- 8.1 The tariff category and the tariff applicable to the Consumer are stated in the Schedule. The rates of tariff of these tariff categories are subject to revision, as approved from time to time by the Commission.
- 8.2 The Consumer is periodically provided with a Statement of Electricity Account (or "the Bill") with the Licensee, showing, among other things, the charges due to the Licensee in respect of the supply of electricity to the Consumer. The contents and periodicity of this Statement are more fully described in the Supply Services Code.
- 8.3 Any other services related to electricity supply as required by the Consumer, is chargeable on the basis of the allowed rates or charges as approved periodically by the Commission. Upon request by the Consumer, the Licensee shall furnish a reasonable breakdown of charges with respect to any services provided or to be provided.

## **9. Security Deposit**

Subject to provisions of Sri Lanka Electricity Act, No. 20 of 2009, the Licensee may require the Consumer to provide a reasonable security for the payment of any moneys which may become due to the Licensee. The amount of such deposit is stated in the Schedule and may be revised by the Licensee from time to time. The procedures adopted by the Licensee for making, revision, payment of interest for and refund of the Security Deposit are more fully described in Supply Services Code.

## **10. Payment of Charges**

10.1 The Consumer shall settle the total charges due to the Licensee in respect of the supply of electricity to the Consumer within the grace period as specified in the Supply Services Code. Failure to settle the Bill by the Consumer within the requisite period may result in:

- i. A liability to a late payment charge at a rate approved by the Commission; and/or
- ii. Subject to provisions of Sri Lanka Electricity Act, No. 20 of 2009, disconnection of the electricity supply to the Consumer.

The procedures applicable to settlement of Bills are more fully described in the Supply Services Code.

10.2 The Licensee may, at his sole discretion, may provide concessions to the Consumer on settlement of Bills.

10.3 The provisions of this Section shall survive the expiry or termination of this Agreement and continue to have effect in terms of this Agreement.

## **11. Disconnection of Supply**

11.1 Subject to applicable law, the supply of electricity to the Consumer may be disconnected:

- i. Temporarily or permanently, upon written request by the Consumer;
- ii. For non-payment of a deposit, instalments of payments or undisputed charges due to the Licensee on the respective due dates;
- iii. having failed to comply with a notice from the Licensee requiring the Consumer to cease using any appliance which unduly or improperly interferes with the supply of electricity by the Licensee to any other consumer;
- iv. without giving any prior notice, if such disconnection can be justified on grounds of safety;
- v. for offences identified under Section 7.5 of this Agreement;
- vi. If the Consumer intentionally or negligently damages or causes to be damaged: -
  - a. any electrical plant or electric line belonging to or operated by the Licensee or any other licensee; duly licensed by the Commission; or
  - b. any part of any domestic electricity supply equipment belonging to or operated the Licensee that is situated on his or her property; or
- vii. upon termination of this Agreement.

## **12. Re-connection**

12.1 If all other circumstances remain unchanged, and subject to any applicable guideline made by the Commission, a supply disconnected from the Consumer's Premises may be reconnected under the same terms and conditions of this Agreement, after the cause that warranted disconnection is remedied.

12.2 The Consumer would be required to enter in to a fresh Agreement with the Licensee, if any of the circumstances falling under the Schedule is changed.

12.3 The fees for reconnection shall be as directed by the relevant rule of the Commission.

## **13. Termination of the Agreement**

This Agreement may be terminated:

13.1 By the Consumer:

- i. by giving 7 days' notice to the Licensee in writing after settlement of all dues to the Licensee, if the Consumer no longer requires the electricity supply;
- ii. by giving 2 days' notice to the Licensee in writing after settlement of all dues to the Licensee if the Consumer intends or has quit the Premises, and;
- iii. by giving 14 days' notice to the Licensee in writing upon any material breach by the Licensee of any term and condition of this Agreement, which remain not remedied after 30 days of bringing the breach to the notice of the Licensee.

13.2 By the Licensee, by giving 14 days' notice to the Consumer in writing: -

- i. Subject to applicable law, upon permanent disconnection of the supply of electricity under Sections 11.1 (ii), (iii), (iv), (v), (vi) of this Agreement.
- ii. upon any material breach by the Consumer of any term or condition of this Agreement, which remain not remedied after 30 days of bringing the breach to the notice of the Consumer.

13.3 Automatically: -

- i. Upon ceasing of ownership of the Premises by the Consumer;
- ii. Upon ceasing of occupancy of the Premises by the Consumer;
- iii. Upon the demise of the Consumer, or;
- iv. Upon discovery of any forged documentation (or any copies of them) presented by the Consumer to the Licensee as related to ownership or occupancy of the Premises or identity of the Consumer.

Subject to applicable law, any guidelines made by the Commission in relation to these events will prevail upon and subsequent to their occurrence.

## **14. Dispute Resolution**

14.1 A dispute is considered to have arisen between the Licensee and the Consumer, only when:

- i. The Consumer had lodged a complaint with the Licensee and the Consumer is not in agreement with the resolution provided by the Licensee or the Licensee has not resolved the matter within the specified time period; or
- ii. The Licensee has notified the Consumer that the Licensee is of opinion that the Consumer is in breach of a provision of the applicable law or this Agreement and the Consumer is not in agreement with the opinion of the Licensee or had not remedied the purported breach within the specified time period.

14.2 Any dispute or difference arising out of or in connection with this Agreement shall, in the first instance, be amicably resolved between the Parties.

14.3 Any dispute between the Licensee and the Consumer arising under this Agreement, and not resolved amicably may be referred by the Consumer to the respective Dispute Resolution Officer identified in the Schedule of this Agreement.

14.4 If the dispute remains not settled despite resort to the above provisions, Consumer or the Licensee, as the case may be, may then make use of the provisions for mediation by the Commission as available in the Sri Lanka Electricity Act, No. 20 of 2009 and the rules made thereunder, or resort to any statutory remedy available through that Act.

## **15. Consumer Information**

15.1 Without obtaining the Consumer's prior written consent, the Licensee shall not disclose any information with regard to the Consumer (including the details of consumer account, consumption of electricity and payments) to any party other than:

- i. the Commission;

- ii. those as required by law;
- iii. as ordered by any court of competent jurisdiction in Sri Lanka;
- iv. a government department or any governmental agency in Sri Lanka, having jurisdiction to the extent required by the applicable rules; or,
- v. as required by regulations of any regulatory body in Sri Lanka.

15.2 The provisions of this Section shall survive the expiry or termination of this Agreement and continue to have effect in terms of this Agreement.

## **16. Assignment**

The Consumer shall not assign or in any other way transfer the rights or obligations under this Agreement, Addendum (if any) or any part thereof to any other party without prior written approval of the Licensee.

## **17. Entire Agreement**

This Agreement, the Schedule, Addenda and respective Annexes (if any), attached hereto, constitute the entire agreement and supersede all prior agreements and understandings, both written and oral, between the Parties with respect to the subject matter hereof.

## **18. Governing Law**

This Agreement shall be governed by and construed in accordance with the laws of Sri Lanka.

## **19. Notices**

All notices, Bills and other communications hereunder shall be in writing (and shall be deemed given upon receipt) if delivered personally by courier (which is confirmed) or to electronic addresses (shall be deemed received when it reaches the addressee's electronic address) or mailed by registered mail to the Parties at the addresses (or at such other address for a Party as shall be specified by like notice) provided in the Schedule.

## **20. Regulatory Compliance**

The Licensee and the Consumer acknowledge that they are governed and/or guided by Sri Lanka Electricity Act, No. 20 of 2009 and Regulations made thereunder on the matters related to the subjects of this Agreement.

The Licensee and the Consumer acknowledge that they are governed and/or guided by any rules or guidelines, as applicable, made by the Commission from time to time on the matters related to the subjects of this Agreement.

## **21. Severability**

If any provision or Section of this Agreement is rendered invalid by any court of competent jurisdiction, the invalidity of such provision or Section shall not affect any of the remaining provisions of this Agreement; provided only where such remaining provision or section is entirely independent of the provision or Section that is rendered invalid.

## **22. Warranties**

The Consumer represents and warrants that:

- 22.1 No other electricity supply connection is or will be obtained for the same Premise, and;
- 22.2 Any supporting documents furnished by the Consumer to the Licensee during the tenor of the Agreement are true and authentic.

## **23. Waiver**

Any waiver made by the Licensee or the Consumer of a breach of this Agreement shall not be treated as a waiver of any further breach of the same or any other provision of this Agreement.





## THE SCHEDULE

---

### S.1 Previous Schedules

Parties agree that all previous schedules that have been executed with the Consumer for this Premise shall be void and shall have no effect after this Schedule is executed on the date given below.

### S.2 Consumer

The Consumer shall mean the person whose particulars are furnished in the following table.

1	Full Name	
2	(For natural persons/ foreign nationals) National Identity Card <sup>1</sup> / Passport No.	
3	(For Ministries or Government Departments) Name of the entity	
4	(For other bodies corporate) Incorporation by <sup>2</sup>	
5	(For Companies) Company Registration No. under Companies Act, No. 07 of 2007	
6	Address <sup>3</sup>	
7	Electronic address (if any)	

### S.3 Description of Consumer's Premises where the supply is connected

1	Assessment No. (if not available, description)	
2	Local Authority Area /subdivision	
3	Address of the Premise	
4	Whether the Consumer is the owner or occupier	Owner / Occupier
5	If Occupier, the basis of occupation	Rent Agreement / Lease / other <sup>4</sup>

<sup>1</sup> Sri Lankan citizen must give the NIC No. Foreign nationals must give the Passport with a valid visa of entry

<sup>2</sup> Please give the name of the Act of incorporation or other instrument which had incorporated the body corporate

<sup>3</sup> In the case of Companies, please give the address of the principal place of business

<sup>4</sup> Please add the reference to the document

#### S.4 Contract Demand

Connection Type <sup>5</sup>	Contract Demand
Single phase Alternating Current	15A
Single phase Alternating Current	30A
Three phase Alternating Current	30A
Three phase Alternating Current	60A
Demand less than or equal to 42 kVA and metered at Low Voltage	[ ] kVA
Demand more than 42 kVA and metered at High Voltage	[ ] kVA

**S.5 Purpose of Use / Consumer Category:** General /Government /Hotel /Industrial / Religious/ Domestic  
**Industry Classification<sup>6</sup>** (For Industrial Use only): NNNN

#### S.6 Type of the connection and the applicable Tariff<sup>7</sup>

Type of the connection	Tariff category
Single / Three/ phase / Alternating Current 30A / 60A	
Net Metering	
Net Accounting	
Net Plus	
Contract Demand less than or equal to 42 kVA	
Contract Demand more than 42 kVA	
Supply at 11 kV or above	

#### S.7 Limitations for the power factor to be maintained by the Consumer<sup>8</sup>

Maximum Demand at the Metering Point	Minimum Power factor at the Metering Point
30A	
60A	
[ ] kVA	

- a. Nominal voltage of supply by the Licensee : V  $\pm$  6% (for medium and low voltage supply) AC
- b. Nominal voltage of supply by the Licensee : kV  $\pm$  10% (for high voltage supply) AC

<sup>5</sup> Remove the rows which are not applicable

<sup>6</sup> According to Gazette Extraordinary No. 1904/58 - of March 06, 2015

<sup>7</sup> Remove the rows which are not applicable

<sup>8</sup> Remove the rows which are not applicable

- c. Nominal frequency of supply by the Licensee:  $50 \text{ Hz} \pm 1\%$
- d. Earthing: The Consumer shall not combine the neutral and protective functions in a single conductor at the Consumer's installation.

The Consumer is advised that the supply voltage, frequency and earthing are subject to the requirements specified by Electricity (Safety, Quality and Continuity) Regulations made by the Gazette Extraordinary No.1975/44 dated 2016.07.13 and any amendment thereto.

### S.8 Metering Point

The Metering Point is as indicated in diagram below:

#### A. Applicable for Single phase Alternating Current 15A/30A/Three phase Alternating Current 30A/60A

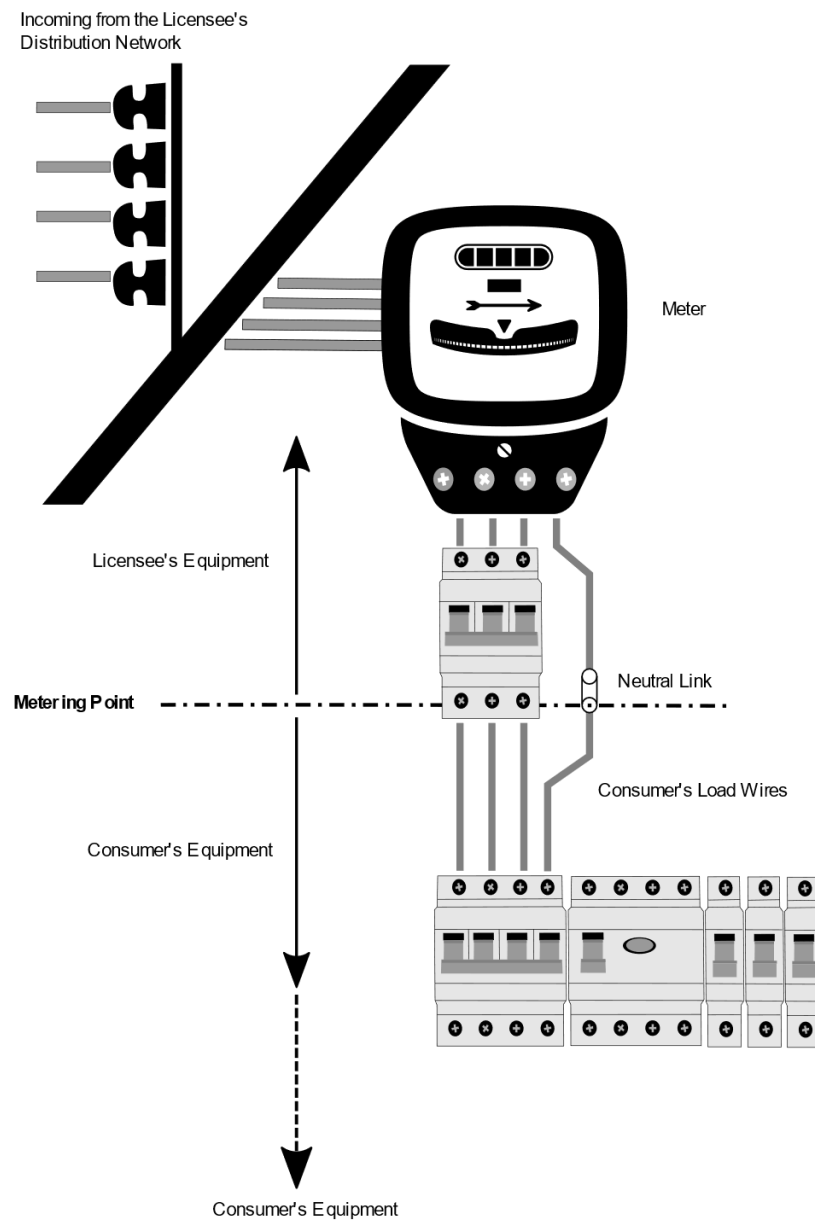

*Note: Shown here is the typical set-up for a three-phase installation. A Single-phase installation will have appropriate lesser number of poles in respective MCBs.*

**B. Applicable for Demand less than or equal to 42 kVA and metered at Low Voltage**

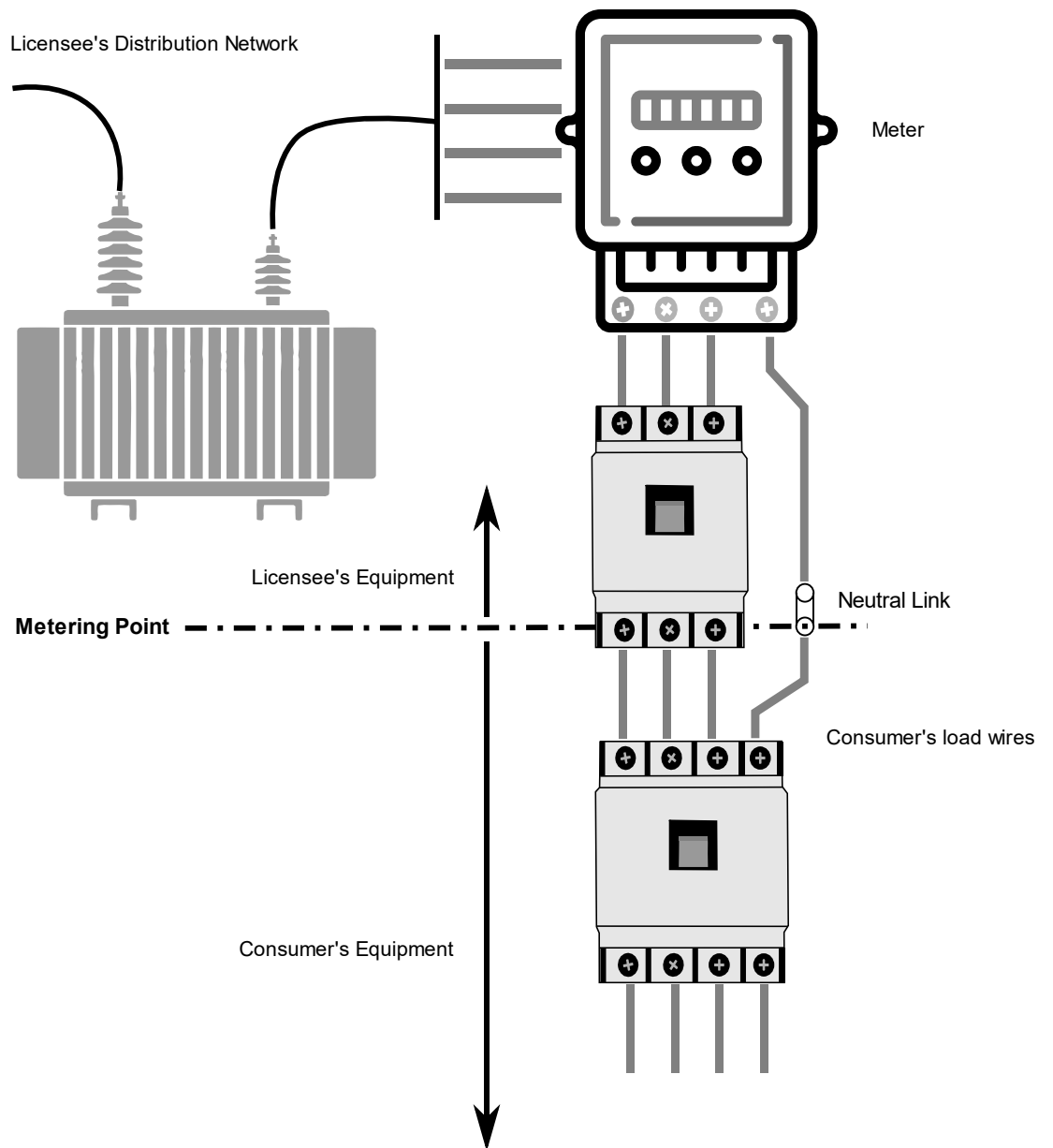

**C. Applicable for Demand more than 42 kVA and metered at High Voltage**

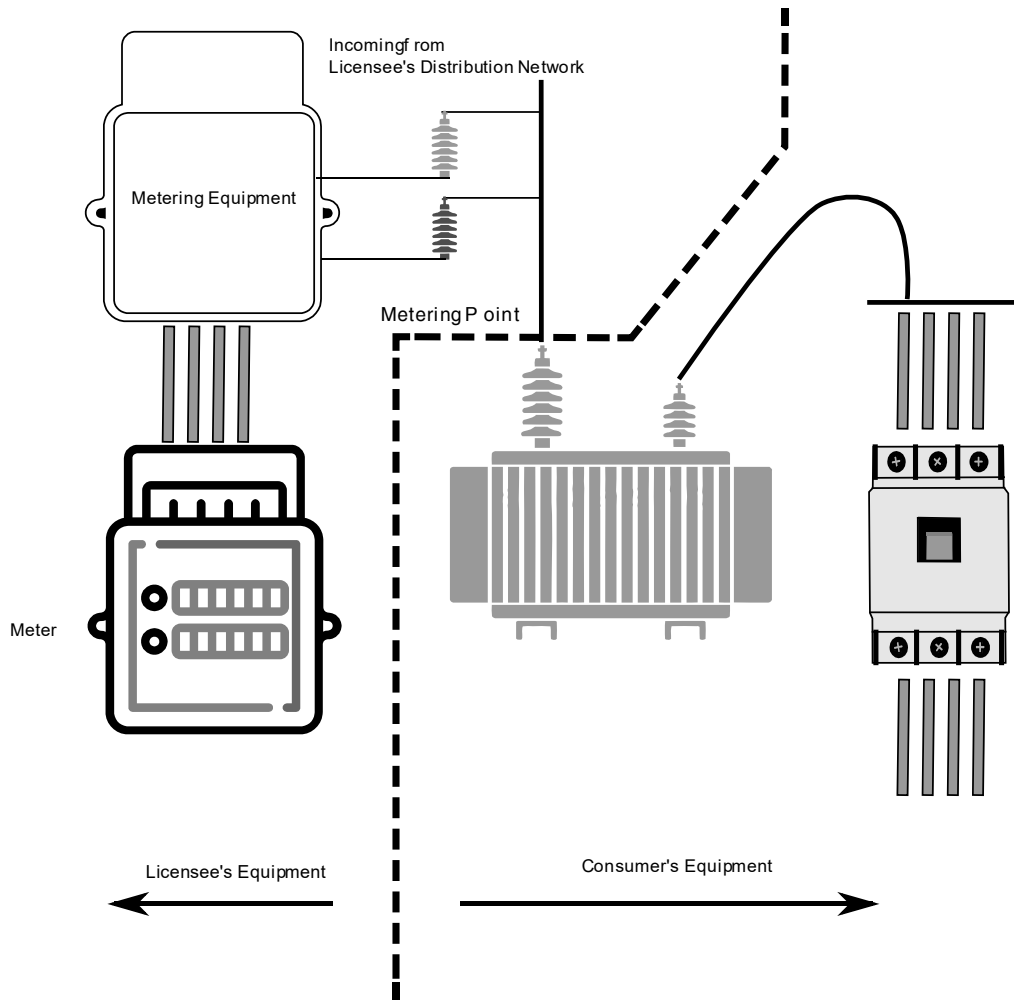

**S.9 Dispute Resolution Officer**

In terms of the Electricity (Dispute Resolution Procedure) Rules made by the Commission, the Dispute Resolution Officer under this Agreement is:

Deputy General Manger ( ) Province

Ceylon Electricity Board

[Address]

**Head of Operations**

**Lanka Electricity Company (Pvt) Limited**

[Address]

**S.10 Notices**

		If to the Licensee	If to the Consumer
1	To	Area Engineer / Branch Manager Area /Branch	
2	Address <sup>9</sup>		
5	Electronic address (if any)		
6	Facsimile (if any)		

IN WITNESS WHEREOF the Parties have executed this Agreement on this day of 20 in Sri Lanka.

Name of the <b>Licensee</b>	Full Name of the <b>Consumer</b>
<b>Authorised officer of the Licensee</b>	<b>Authorised officers of / The Consumer</b>
Signature:	Signature:
	Name:
	National Identity Card No:
	Position:
Name:	Signature:
Position:	
	Name:
	National Identity Card No:
	Position:

<sup>9</sup>In the case of Companies, please give the address of the principal place of business

