

140-2: 2016

CEB
SPECIFICATION

**AERIAL BUNDLE CONDUCTOR
ACCESSORIES (11kV)**

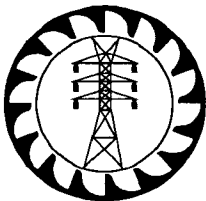

CEYLON ELECTRICITY BOARD
SRILANKA

Telephone: +94 11 232 8051

Fax: +94 11 232 5387

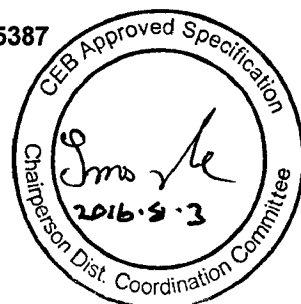

CONTENTS

	Page
1.0 Scope	3
2.0 System Parameters	3
3.0 Service Conditions	3
4.0 Applicable Standards	3
5.0 Basic Features and Technical Requirements	4
6.0 Quality Assurance	7
7.0 Additional Requirements	8
8.0 Inspection and Testing	8
9.0 Information to be furnished with the Offer	10
10.0 Annex	11
Annex A-1: Drawing: Triangular Suspension Bracket	12
Annex A-2: Drawing: Suspension Clamp	13
Annex A-3: Drawing: Tension Bracket	14
Annex A-4: Drawing: 11kV ABC T-Off	15
Annex A-5: Drawing: Details of the 11m/500kg Pole	16
Annex A-6: Drawing: Details of the 11m/850kg Pole	17
Annex B: Schedule of Guaranteed Technical Particulars	18
Annex C: Non-Compliance schedule	20

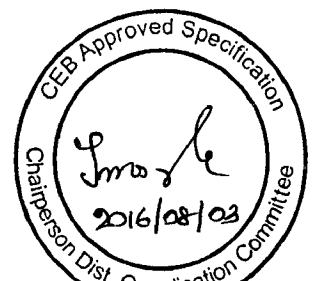

SPECIFICATION FOR AERIAL BUNDLE CONDUCTOR ACCESSORIES (11kV)

1.0 SCOPE

This specification covers the general requirements of design, manufacture and testing of 6.35/11 (12) kV, U₀/U (U_m) Aerial Bundle Conductor (here in after called "ABC") accessories.

2.0 SYSTEM PARAMETERS

(a)	Nominal voltage	11 kV
(b)	System highest voltage	12 kV
(c)	System frequency	50 Hz
(d)	Method of earthing	Non Effectively Earthed
(e)	System fault level	25 kA
(f)	Fault duration	1 s

3.0 SERVICE CONDITIONS

(a)	Annual average ambient temperature	30 °C
(b)	Maximum ambient temperature	40 °C
(c)	Maximum relative humidity	90%
(d)	Environmental conditions	Humid tropical climate with heavily polluted atmosphere
(e)	Operational altitude	From M.S.L. to 1900 m above M.S.L.
(f)	Isokeraunic (Thunder days) level	100 days
(g)	Maximum solar radiation	4.5 kWh/m ² /day

4.0 APPLICABLE STANDARDS

The equipment and components supplied shall be in accordance with, but shall not be limited to, the latest editions of the standards specified below and amendments thereof.

i.	IEC 61284:1997	Overhead lines –Requirements and tests for fittings
ii.	BS EN 10025:2004	Hot rolled products of structural steels
iii.	BS EN ISO 1461:2009	Hot dip galvanized coatings on fabricated iron and steel articles – specifications and test methods
iv.	IEC 60243-1:2013	Electric strength of insulating materials - Test methods - Part 1: Tests at power frequencies
v.	IEC 61442: 2005	Test methods for accessories for power cables with rated voltages from 6 kV (U _m = 7,2 kV) up to 30 kV (U _m = 36 kV)
vi.	NFC 33 040:2013	Insulated cables and their accessories for power systems - Suspension equipment for overhead distribution with bundle assembled cores, of rated voltage 0,6/1 Kv
vii.	NFC 33 041:2013	Insulated cables and their accessories for power systems - Anchoring devices for overhead distribution with bundle assembled cores of rated voltage 0,6/1 Kv

Offers of items manufactured to any other internationally recognized standards or specifications that are compatible to the above standards shall be accompanied with an English translation of such standards and specifications.

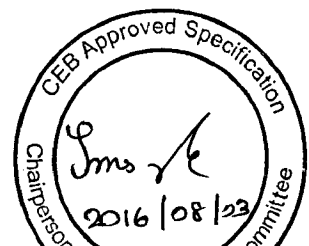

5.0 BASIC FEATURES

The accessories for ABC rated at 6.35/11 (12) kV, $U_0/U (U_m)$ are as specified below and they should satisfy all the loadings and tests as stipulated therein. All the accessories for ABC should have characteristics conforming to relevant standards and specifications. The ABC system considered shall have cross sections of 95mm^2 or 150mm^2 of phase conductors and insulated galvanized steel messenger wire with sufficient breaking load. The accessories for ABC system shall be suitably designed to install on 11m/500kg and 11m/850kg Pre Stressed Poles as stipulated in Annex A-5 and A-6.

5.1 Clamps and assembly

The clamps and assembly for ABC specified below shall satisfy the requirements as stipulated therein.

- (a) Suspension Small Angle Assembly
 - i. Triangular Suspension Bracket
 - ii. Suspension clamp and movable connecting (articulated) link
- (a) Dead End Assembly
 - i. Tension Bracket
 - ii. Wedge Type Tension(Dead End) Clamp
- (b) Large Angle Assembly

5.1.1 Suspension Small Angle Assembly

Suspension assembly shall be suitable for use on overhead lines of rated voltage 6.35/11 kV with bundled insulated conductors stretched between poles. Suspension assemblies shall be installed to hold the insulated messenger wire.

The assembly shall also be suitable for use on 'out of aligned' poles with the angles of deviation such that the maximum angle is 45° for salient angles and 27° for re-entrant angles.

The dimensions of the components shall be such that the suspension clamp does not touch the pole at re-entrant angle locations.

The assembly shall consist of the following three components.

- a) One number triangular suspension bracket
- b) One number movable connecting (articulated) link
- c) One number suspension clamp

5.1.1.1. Triangular Suspension Bracket

Suspension bracket shall be of triangular shape made from C-channel iron suitable for attachment to a rectangular concrete pole by two galvanized iron bolts. It shall be designed to withstand a minimum breaking load of 30kN.

The Triangular Bracket shall consist of one (1) no. of main C-channel Iron, two (2) nos. of mild steel flat bar attached to the main C-channel Iron via four (4) bolts and nuts and one (1) unit of U-bolt complete with four (4) suitable nuts and washers. The mild steel bar shall be provided with a suitable diameter round hole to accommodate MV ABC cable rollers during stringing.

The nuts, studs, "U" bolts, bolts and nuts, mild steel bars and the C-channel iron shall be galvanized in accordance to BS EN ISO 1461 standard.

The triangular bracket shall be smooth and free from edges that could damage the Aerial Bundled Conductor or cause injuries to the installer or user. It shall be designed to best performance and reliability so that persons and surrounding will not be exposed to any dangers.



Preferred conceptual drawing of the triangular suspension bracket is indicated in Annex A-1. Manufacturer may propose alternative designs based on the conceptual design with the adherence to the main functional requirements of suspension brackets. Proposed designs shall be in accordance with the specifications of the poles indicated in Annex A-5 and A-6. Relevant design drawings and documentation complete with the dimensions, tolerances, and description shall be attached in the submission.

5.1.1.2. Suspension Clamp and Connecting (articulated) Link

The Suspension Clamp and the connecting link shall be made of weather resistant and corrosion proof material. Suspension Clamp shall be designed to withstand a minimum breaking load of 20kN and shall also be capable to withstand up to 6.35kV power frequency voltage. Connecting link shall be capable to act as a mechanical fuse in case of overloading on the bundled conductor (when breaking, suspension assembly releases the cables preventing the disruption at the dead end) which has a suitable breaking load less than the breaking load of suspension clamp.

The main body of the suspension clamp shall be fully insulated with adequate thickness. Internal shape of the suspension clamp shall allow the messenger to a turning angle not less than 45° inside the clamp.

Clamping of the messenger shall be capable of controlling slippage. This device shall have the capacity for suspension and tightening the messenger wire. A bolt on the clamp body is preferred method to lock the messenger wire to the clamp body. During installation of ABC system it shall be possible to suspend the messenger wire in the open clamp before it is locked by the bolt.

Preferably a hole with minimum size 20mm x 10mm shall be provided at the end of the clamp body. The hole shall be suitable to be used for strapping an insulated binding strap (as per clause 5.3.2) through it for supporting the phase conductors from sagging away from the clamp.

Clamping messenger wire to the insulated suspension clamp shall not require any special tools. The suspension clamp shall be designed such that it does not have any loose parts. Overall design of the clamp shall allow the interconnection between 6.35/11kV rated ABC insulated messenger wire and the triangular bracket on the pre-stress concrete pole with ease and without damaging them or causing the ABC messenger wire from slipping out of its intended position from the suspension clamp.

Preferred conceptual drawing of the Suspension Clamp is indicated in Annex A-2. Manufacturer may propose alternative designs based on the conceptual design with the adherence to the main functional requirements of suspension clamp. Proposed designs shall be in accordance with the specifications of the poles indicated in Annex A-5 and A-6. Relevant design drawings and documentation complete with the dimensions, tolerances, and description shall be attached in the submission.

5.1.2 Dead End Assembly

Dead end assembly shall be suitable for anchoring of overhead lines of rated voltage 6.35/11 kV with bundled insulated conductors stretched between poles. Dead end assembly shall be installed to hold the messenger wire.

The assembly shall consist of the following two components.

- a) One number tension bracket
- b) One number tension clamp

5.1.2.1. Tension Bracket

The Tension Bracket shall consist of one (1) no. of main C-channel Iron, one (1) no. of hinge bolt and one (1) no. unit of 16mm shackle. Two (2) nos. of studs and four (4) nos. of nuts with washers shall be supplied together with the tension bracket.

The shackle shall be connected to the C-channel iron by a hinge bolt as illustrated in AnnexA-3. The hinge bolt shall be locked in place by a washer and a nut. The shackle shall be designed



such that it shall be possible to remove the shackle from the C-channel iron by removing the hinge bolt.

The C-channel iron shall be provided with two through holes for mounting it to concrete poles. The nuts, studs, bolts and the C-channel iron shall be galvanized in accordance to BS EN ISO 1461.

The tension bracket shall be designed to withstand a minimum breaking load of 31kN. It shall be smooth and free from edges that could damage the Aerial Bundled Conductor or cause injuries to the installer or user. It shall be designed to best performance and reliability so that persons and surrounding will not be exposed to any dangers.

Preferred conceptual drawing of the tension bracket is indicated in Annex A-3. Manufacturer may propose alternative designs based on the conceptual design with the adherence to the main functional requirements of tension bracket. Proposed designs shall be in accordance with the specifications of the poles indicated in Annex A-5 and A-6. Relevant design drawings and documentation complete with the dimensions, tolerances, and description shall be attached in the submission.

5.1.2.2. Tension (Dead End) Clamp

Tension clamps shall be suitably designed to anchor the bundled conductor on the messenger wire. The Tension Clamp shall be designed to withstand a minimum breaking load of 31kN and shall be capable of withstanding 6.35kV power frequency voltage.

Housing of the tension clamp shall be made out of weather resisting material. All components shall be unlosable. In all cases, it shall be possible to install the cable clamp without using any special tool.

To ease the torsional movement involved in the ABC system, the clamp shall be supplied with a suitable stainless steel attachment to the above tension bracket. The Clamp shall be exclusively made of weather resistant insulating material and shall be designed to withstand the relevant breaking load of the messenger wire without slipping.

All the components shall be made of corrosion resistant materials. Manufacturer may propose alternative design based on the requirements stipulated here. Proposed designs shall adhere to the main functional requirement of the dead end clamp and specifications of the poles indicated in Annex A-5 and A-6.

5.1.3 Large Angle Assembly

Each assembly shall include:

- (a) One number Tension Bracket with Two Shackles.
- (b) Two numbers Tension Clamps.

Description of sub components of the large angle assembly are the same as for the dead end assembly described in Clause 5.1.2. above, but two Tension Clamps and one tension bracket with two Shackles shall be supplied instead of one Tension Clamp as in the Dead End Assembly.

5.2 T- offs and Straight Through Joints

T-offs and straight through joints in ABC system are used to interconnect three or two ABC lines. Following components shall contain in a 6.35/11 (12) kV ABC T-off joint.

- (a) Dead end assemblies for each cable end
- (b) Insulator Mounting Bracket
- (c) Connection Cover
- (d) PG Clamp, Bi-Metal, (For earthing arrangement)
- (e) PG Clamp, Al, (suitable for messenger wire)
- (f) HV ABC Termination Kit 95mm²/150mm²
- (g) Surge Arrester 11kV, 10kA
- (h) Copper Bus Conductor Plate

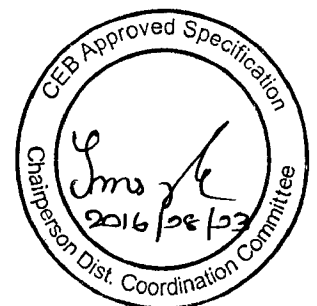

- (i) Copper Bus Conductor Plate, T-Off
- (j) Conductor Crimping Ferrule (suitable for messenger wire)
- (k) Eye Lugs (For earthing arrangement)
- (l) Split Bolt -type D (For earthing arrangement)

Preferred conceptual drawing is indicated in Annex A-4 in the specification for the T-offs. Manufacturer may propose alternative designs based on the conceptual design with the adherence to the main functional requirements of T-offs. Proposed designs shall be in accordance with the specifications of the poles indicated in Annex A-5 and A-6. Relevant design drawings and documentation complete with the dimensions, tolerances, and description with details about necessary tools required for T-off joint, shall be attached in the submission.

Straight through joints shall be analogous to T-offs, with relevant components indicated above, having ability to connect two ABC lines.

Note: Provision shall be available to earth the Surge Arrester and Cable Sheath Separately.

5.3 Termination Kits and Other Accessories

5.3.1 Termination Kits.

The termination kits shall be designed and manufactured to IEC 61442 and shall be of heat shrinkable material suitable for use in terminating ABC having aluminum stranded conductors.

The termination shall be complete with all components and materials necessary for terminating cables of specified size. The components and materials for each category of termination shall include the following items.

- (a) Internal insulation tubing
- (b) Stress control tubing
- (c) Anti-track tubing
- (d) Moisture sealant
- (e) Compression/mechanical lugs for appropriate size of the cable
- (f) Sufficient duty earth strip
- (g) Constant tension clips
- (h) Insulation boots for indoor termination and shields to increase creepage for outdoor termination. Boots are either angle or straight depending on the use.
- (i) Cable break out to separate the cores.

The termination kits shall be designed and manufactured to ensure that all components and materials shall be weather resistant. The components and materials shall be manufactured to ensure high moisture sealing capacity, proper stress control and resistance to tracking when in service. Relevant design drawings and documentation complete with the dimensions, tolerances, and description with details about necessary tools required for termination kit, shall be attached in the submission

5.3.2 Insulating Binding Strap

The binding strap shall be used for binding the cable at different locations with the tension clamp and suspension clamp.

The strap shall be made of polyamide which is suitable to strap ABC systems up to 150mm² phase conductors with sufficient strength to hold all cable cores tight. The binding strap shall be designed to comply with the dimensions of relevant accessories mentioned in clause 5.1.

There shall be tilted grooves on one side of the strap and the top of the strap shall have a locking and releasing facility.

6.0 QUALITY ASSURANCE

The manufacturer shall possess ISO 9001:2008 Quality Assurance Certification valid throughout the delivery period of this bid, for both manufacture of accessories of ABC (11kV) and the plant where the ABC (11kV) accessories are being manufactured. The Bidder shall furnish a copy of the ISO



certificate certified as true copy of the original by the manufacturer, along with the offer.

7.0 ADDITIONAL REQUIREMENTS

7.1 Manufacturing Experience

The manufacturer shall have minimum of 5 years experience in manufacturing and supply of accessories of ABC (11kV). Manufacturer shall furnish documentary evidence with the offer to prove his manufacturing experience.

7.2 Packaging and Delivery

The Accessories for Aerial Bundled Conductors shall be packed as indicated below. Name of Item and the quantity shall be clearly marked on each packing.

Relevant to items in Clause 5.1

- (a) The complete Suspension Small Angle Assembly shall be delivered in a single pack in a suitable bag.
- (b) The complete Dead End Assembly shall be delivered in a single pack in a suitable bag.
- (c) The complete Large Angle Assembly shall be delivered in a single pack in a suitable bag.

Relevant to items in Clause 5.2

Each accessory shall be packed in a strong suitable container to protect from mechanical damage. Individual parts shall be packed in strong sealed plastic bags to protect them from ingress of dirt and moisture. The container shall have:

- (a) Installation instructions indicating the tools required for each stage all in English Language.
- (b) All necessary components and consumables required to complete the installation as per the Clause 5.2.
- (c) Packing shall be such as to permit easy identification of the components without their removal of packaging.

Relevant to items in Clause 5.3

Each accessory shall be packed in a strong cardboard container to protect from mechanical damage. Individual parts shall be packed in strong sealed plastic bags to protect them from ingress of dirt and moisture. The cardboard container shall have:

- (a) Installation instructions indicating the tools required for each stage all in English Language.
- (b) All necessary components and consumables required to complete the installation as per the Clause 5.3.
- (c) Packing shall be such as to permit easy identification of the components without their removal of packaging.

8.0 INSPECTION AND TESTING

8.1 Type Tests

The equipment/items shall be subjected to the following Type Tests, in accordance with the relevant standards specified in clause 4.0.

Type Tests Relevant to items in Clause 5.1

- (a) Mechanical Test



- i. Tensile tests on brackets
 - ii. Tensile tests on sub-assemblies
 - iii. Slippage test on the clamp of the suspension assemblies
- (b) Voltage tests on sub-assembly suspension clamp & connecting link
 - (c) Ageing Test
 - (d) Corrosion test
 - (e) Hot dip galvanizing test according to BS EN ISO 1461 for tension and suspension brackets.

Type Tests Relevant to items in Clause 5.2

- (a) Voltage and water tightness test
- (b) Temperature rise and over current tests
- (c) Climatic ageing test
- (d) Installation tests at Low temperature
- (e) Mechanical test
- (f) Corrosion test
- (g) Electrical ageing test

Type Tests Relevant to items in Clause 5.3.1

- (a) AC voltage test
- (b) DC voltage test
- (c) Voltage and water tightness test
- (d) Impulse Voltage test
- (e) Partial discharge test
- (f) Heating cycle voltage tests
- (g) Impact test at ambient temperature
- (h) Screen resistance measurement
- (i) Screen leakage current measurements

Test Certificates based on the type tests conforming to the relevant standard shall be supplied along with the offer for evaluation purpose.

Test certificates referred to shall be from an **accredited independent testing laboratory acceptable to the purchaser**. Proof of accreditation by a national/ international authority shall be forwarded with the offer. Test reports shall be complete including all the pages as issued by the testing authority. Parts of test reports shall not be acceptable.

8.2 Routine Tests

While manufacturing each batch of equipment/item shall be subjected to the Routine Tests conforming to the standards specified in clause 4.0.

8.3 Inspection

The Successful bidder shall make necessary arrangements for pre-shipment inspection by an Inspector sent by the CEB and to carry out in his presence necessary Sample / Acceptance tests on equipment and material offered. Routine test reports shall also be made for the observation of the inspector. CEB may waive off the inspection with the condition of carrying out the acceptance tests by an independent testing authority acceptable to CEB. In such a situation a notice of waive off will be issued in advance to the supplier.

8.4 Acceptance / Sample Tests

The following Acceptance /Sample Test shall be witnessed by the engineer appointed by the CEB and shall conform to the relevant standards specified in clause 4.0.

Relevant to items in Clause 5.1

- (a) Mechanical Tests
- (b) Voltage tests on sub-assembly suspension clamp & connecting link
- (c) Galvanizing Test according to BS EN ISO 1461 for tension and suspension brackets



Relevant to items in Clause 5.2

- (a) Voltage and water tightness test
- (b) Temperature rise and over current tests
- (c) Mechanical tests

Relevant to items in Clause 5.3.1

- (a) Voltage and water tightness test
- (b) Impulse Voltage test
- (c) Impact test at ambient temperature
- (d) Screen resistance measurement
- (e) Screen leakage current measurements

8.3 Sample Study

One sample of all types of accessories offered shall accompany the bid to facilitate analysis and evaluation

9.0 INFORMATION TO BE SUPPLIED WITH THE OFFER

The selected Bidder shall supply all relevant drawings, technical literature, handbooks etc. in English, in order to facilitate proper installation.

Routine Test Certificates conforming to the Clause 8.2 shall be furnished with the equipment. The Bid shall be accompanied with the following also;

- a. English version of catalogues describing the equipment and indicating the type/model number.
- b. Technical literature in English describing the constructional and operational features of the equipment.
- c. The standard to which the goods have been manufactured.
- d. Recommended current carrying capacity of the cable joints and terminations.
- e. Dimensional drawings of the conductor accessories.
- f. Other relevant details, design drawings, recommended tools to be used with respect to clauses 5.1.1, 5.1.2, 5.1.3, 5.2 and 5.3.
- g. Packing details.
- h. Completed schedule of particulars as per Annexure B.
- i. Type test certificates for the following items conforming to Clause 8.1
 - i. Suspension, Large Angle and Dead End Assembly,
 - ii. T -Off Assembly
 - iii. Cable Termination kits.

The Bidder shall furnish information to ascertain that manufacturer has over 5 years of manufacturing accessories for ABC.

Failure to furnish the above details, data as per Clause 8.0 and samples as per Clause 8.3 will result in the offer being rejected.

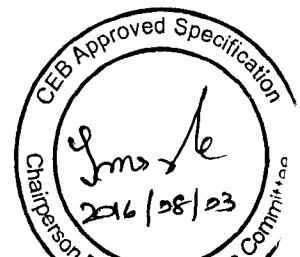

10.0 ANNEX

Annex A-1: Drawing: Triangular Suspension Bracket

Annex A-2: Drawing: Suspension Clamp

Annex A-3: Drawing: Tension Bracket

Annex A-4: Drawing: 11kV ABC T-Off

Annex A-5: Drawing: Details of the 11m/500kg Pole

Annex A-6: Drawing: Details of the 11m/850kg Pole

Annex B- Schedule of Guaranteed Technical Particulars - To be filled by the manufacturer.

Annex C- Non-Compliance schedule – To be filled by the manufacturer/bidder



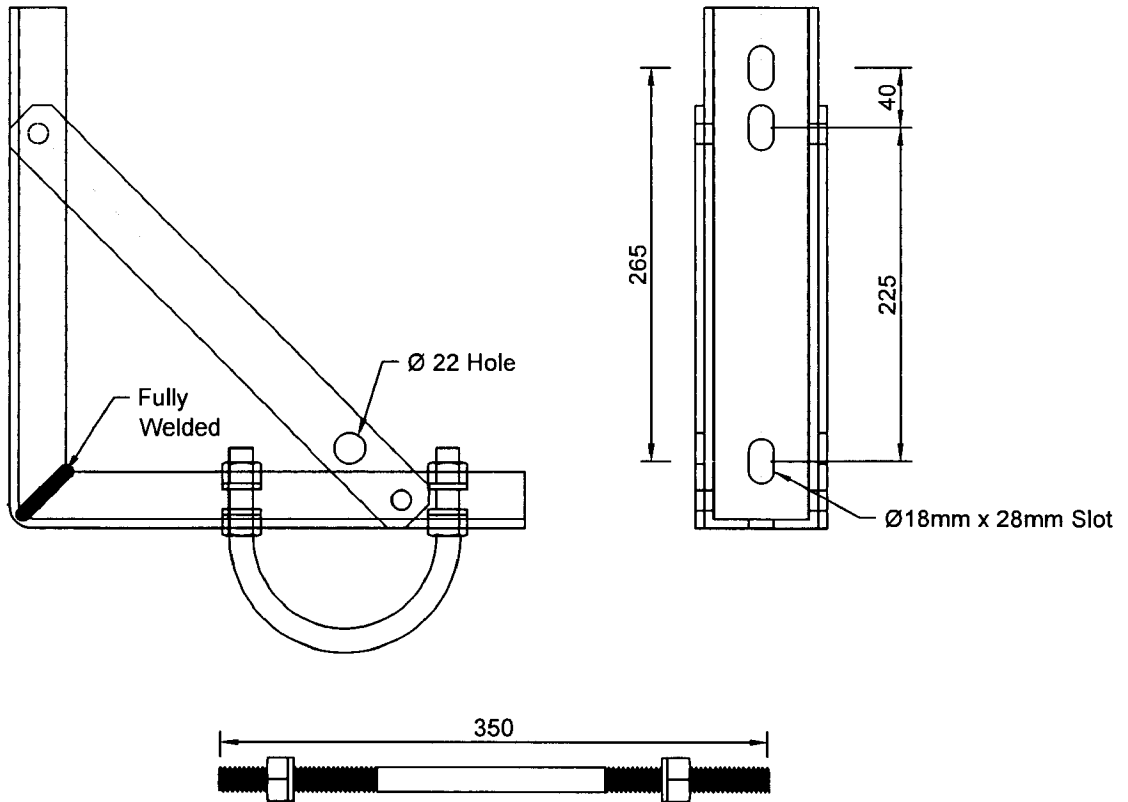

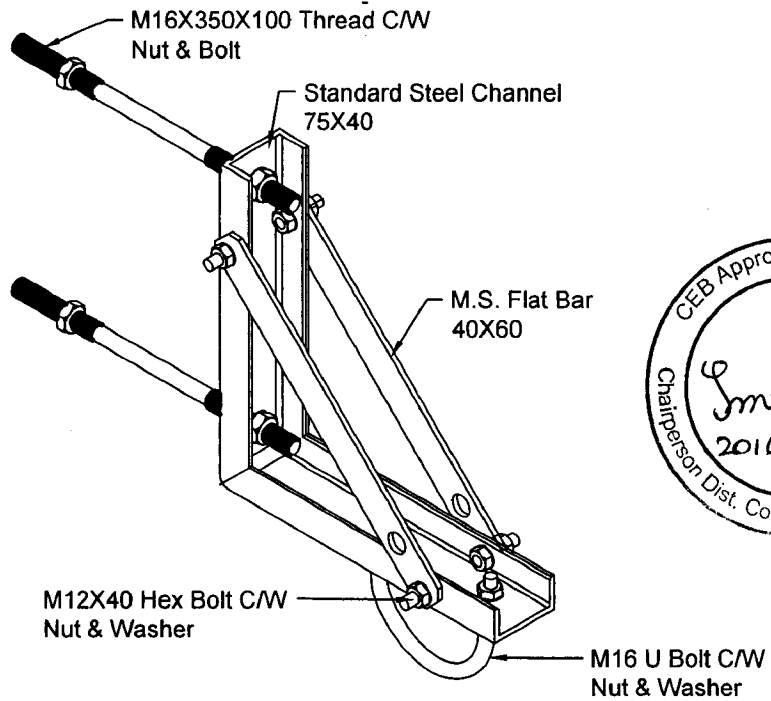

STUD M16 x 350 X 100mm Thread C/W NUTS & WASHER

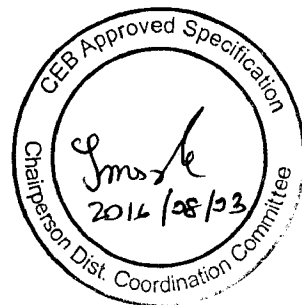
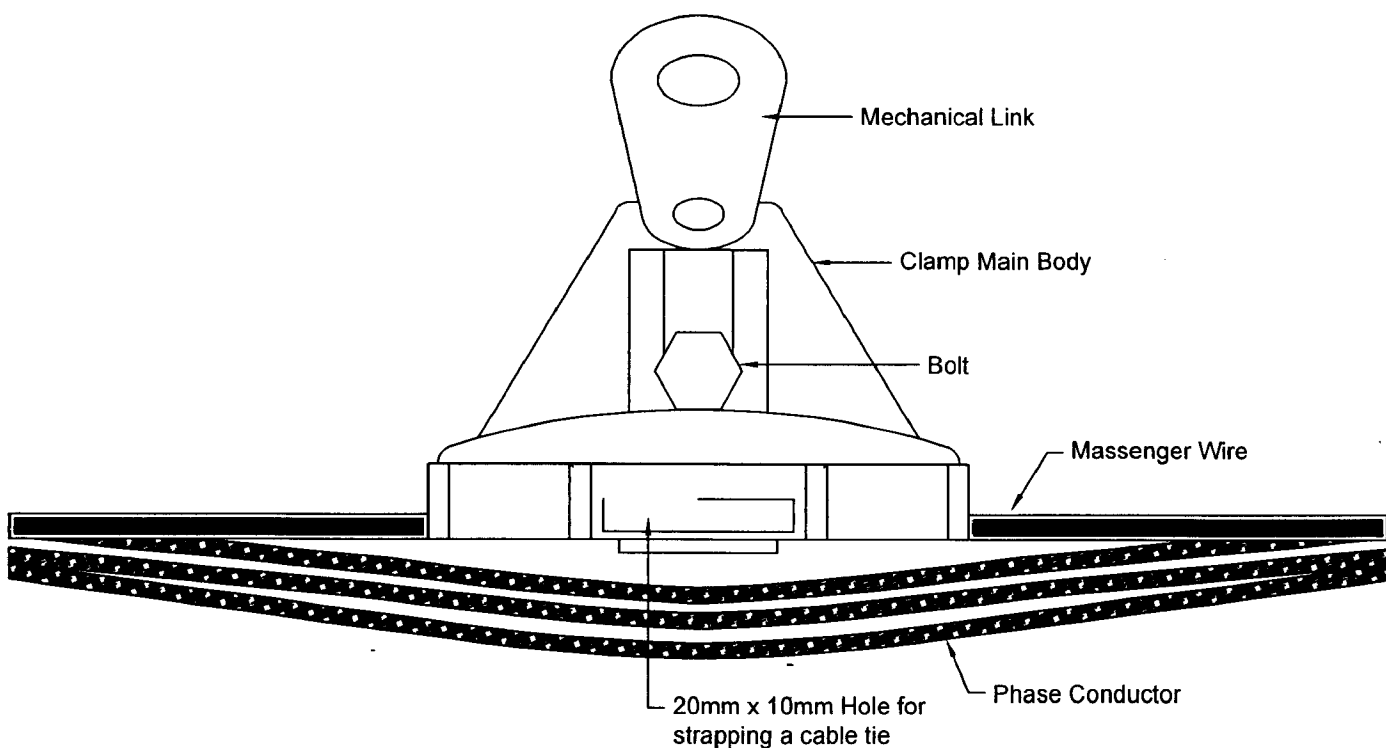

 <p>CEYLON ELECTRICITY BOARD</p>	DISTRIBUTION STANDARDS & SPECIFICATION		SCALE : NOT TO SCALE
	TRIANGULAR SUSPENSION BRACKET		DRAWN : LALANI
	DESIGNED BY	APPROVED BY	DATE : May,2016
			DRG. NO : DS&S/2016/140-2A
DISTRIBUTION COORDINATION BRANCH	EE (DC)	CHAIRMAN, SPECIFICATION COMMITTEE	CAD NO :



 <p>CEYLON ELECTRICITY BOARD</p>	DISTRIBUTION STANDARDS & SPECIFICATION		SCALE : NOT TO SCALE
	SUSPENTION CLAMP		DRAWN : LALANI
DISTRIBUTION COORDINATION BRANCH	DESIGNED BY	APPROVED BY	DATE : May, 2016
			DRG. NO : DS&S/2016/140-2B
	EE (DC)	CHAIRMAN, SPECIFICATION COMMITTEE	CAD NO :

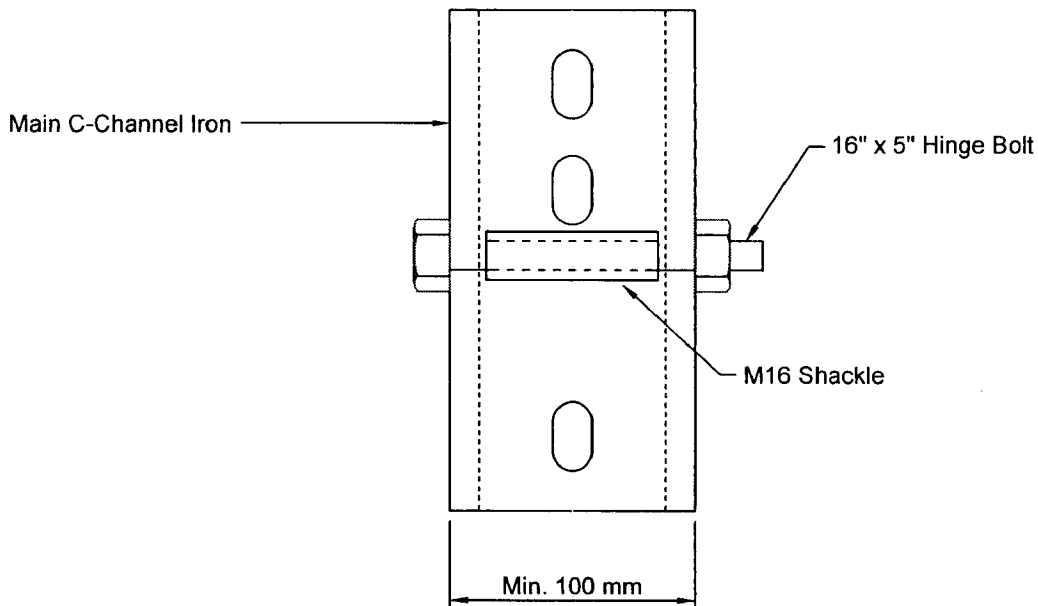

FRONT VIEW SINGLE MV DEAD END CLAMP BRACKET WITH SHACKLE

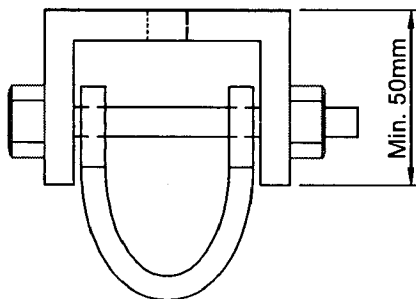

TOP VIEW MAIN C-CHANNEL IRON

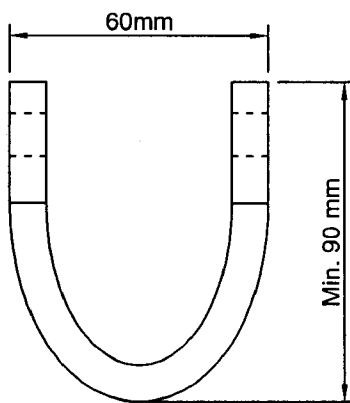

TOP VIEW M16 SHACKLE



 CEYLON ELECTRICITY BOARD	DISTRIBUTION STANDARDS & SPECIFICATION		SCALE : NOT TO SCALE
	TENSION BRACKET		DRAWN : LALANI
	DESIGNED BY	APPROVED BY	DATE : May, 2016
			DRG. NO : DS&S/2016/140-2C
DISTRIBUTION COORDINATION BRANCH	EE (DC)	CHAIRMAN, SPECIFICATION COMMITTEE	CAD NO :

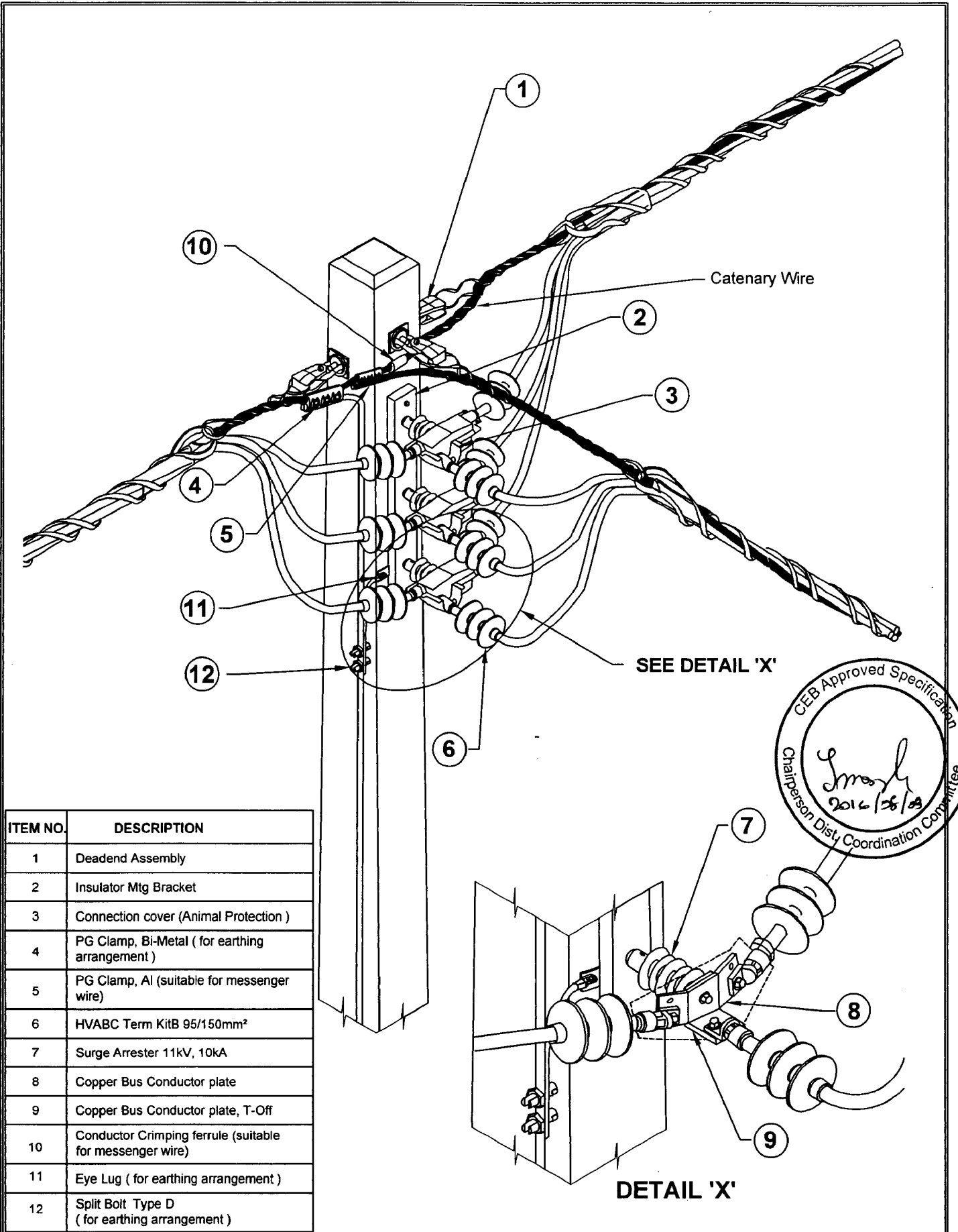

ITEM NO.	DESCRIPTION
1	Deadend Assembly
2	Insulator Mtg Bracket
3	Connection cover (Animal Protection)
4	PG Clamp, Bi-Metal (for earthing arrangement)
5	PG Clamp, Al (suitable for messenger wire)
6	HVABC Term KitB 95/150mm ²
7	Surge Arrester 11kV, 10kA
8	Copper Bus Conductor plate
9	Copper Bus Conductor plate, T-Off
10	Conductor Crimping ferrule (suitable for messenger wire)
11	Eye Lug (for earthing arrangement)
12	Split Bolt Type D (for earthing arrangement)

 **CEYLON ELECTRICITY BOARD**

DISTRIBUTION COORDINATION BRANCH

DISTRIBUTION STANDARDS & SPECIFICATION

11kV ABC T - OFF

DESIGNED BY	APPROVED BY
EE (DC)	CHAIRMAN, SPECIFICATION COMMITTEE

SCALE : NOT TO SCALE
DRAWN : LALANI
DATE : May, 2016
DRG. NO : DS&S/2016/140-2D
CAD NO :

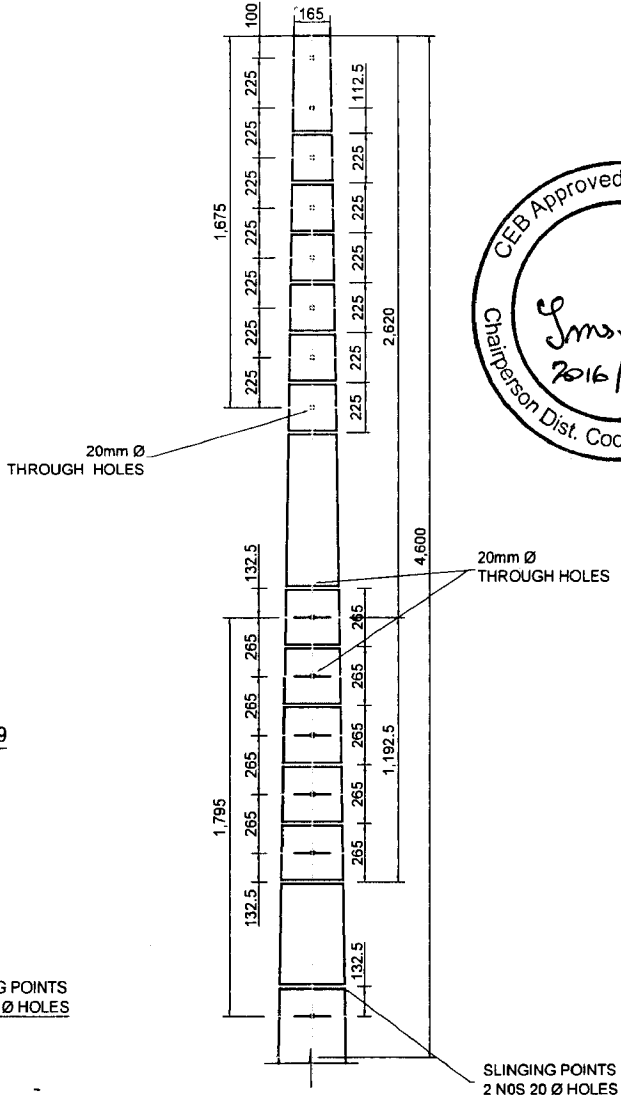
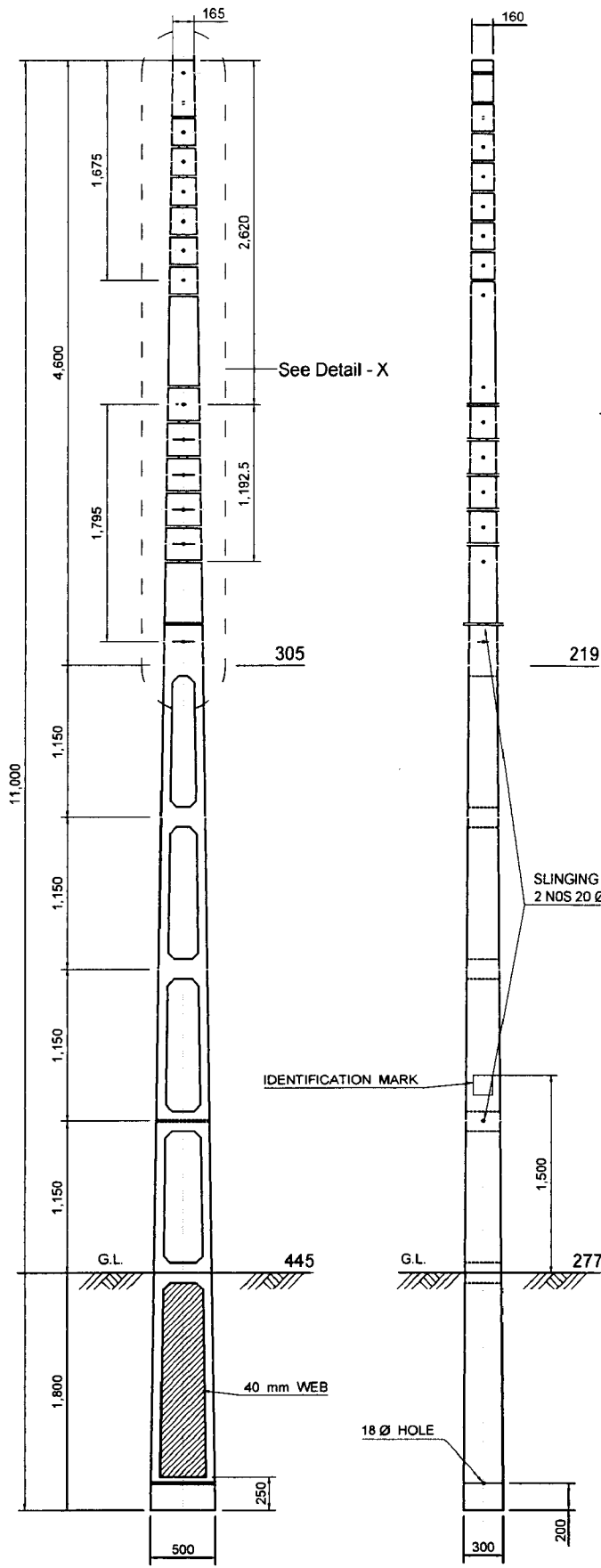
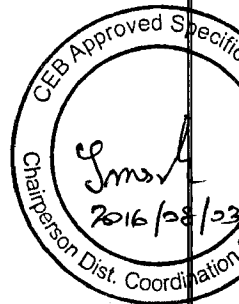

DETAIL X

NOTE

1. CONCRETE TO BE GRADE C40 (NOMINL AGG. SIZE = 15 mm)
2. PRE STRESSING STEEL TO BE Ø 5 mm HIGH TENSILE STEEL WITH MIN. 32 KN CHARACTERISTIC
3. SECONDARY STEEL TO BE 10 mm. TOP STEEL WITH MIN. 450 N/mm² CHARACTERISTIC STRENGTH
4. STIRRUPS & WEB REINFORCEMENT TO BE MILD STEEL HAVING MINIMUM 250 N/mm² CHARACTERISTIC STRENGTH
5. MIN. COVER TO ALL STEEL 20 mm.
6. MIN. SPACING BETWEEN SECONDARY STEEL TO BE 25 mm. MIN. SPACING BETWEEN H.T. STEEL TO BE 20mm.
7. H.T. WIRES DE BONDED (1/2 No. EACH FACE)
2 Nos. FOR THE TOP 1500
2 Nos. FOR THE TOP 1000
8. 10 Nos. Ø6mm MILD STEEL STIRRUPS AT 150 CTRS FROM FROM TOP OF POLE
9. 4 Nos. 5mm UNITENSIONED H.T. WIRES UP TO 6.8 M FROM BOTTOM END
10. ALL HOLES Ø20 mm UNLESS SPECIFIED OTHERWISE.

DESIGN CRITERIA

1. THIS POLE IS DESIGNED FOR A WORKING LOAD OF 500Kg IN THE TRANSVERSE DIRECTION & 125Kg. IN THE LONGITUDINAL DIRECTION, APPLIED AT A POINT 0.6M BELOW TOP OF POLE.
2. FACTOR OF SAFETY - 2.5

ELEVATION

ALL DIMENSIONS ARE IN MM.

	DISTRIBUTION STANDARDS & SPECIFICATION		SCALE : NOT TO SCALE
	11.0 METER 500 KG PRE-STRESSED CONCRETE POLE		DRAWN : LALANI
DESIGNED BY	APPROVED BY	DATE : May, 2016	DRG. NO : DS&S/2016/140-2E
DISTRIBUTION COORDINATION BRANCH	EE (DC)	CHAIRMAN, SPECIFICATION COMMITTEE	CAD NO :

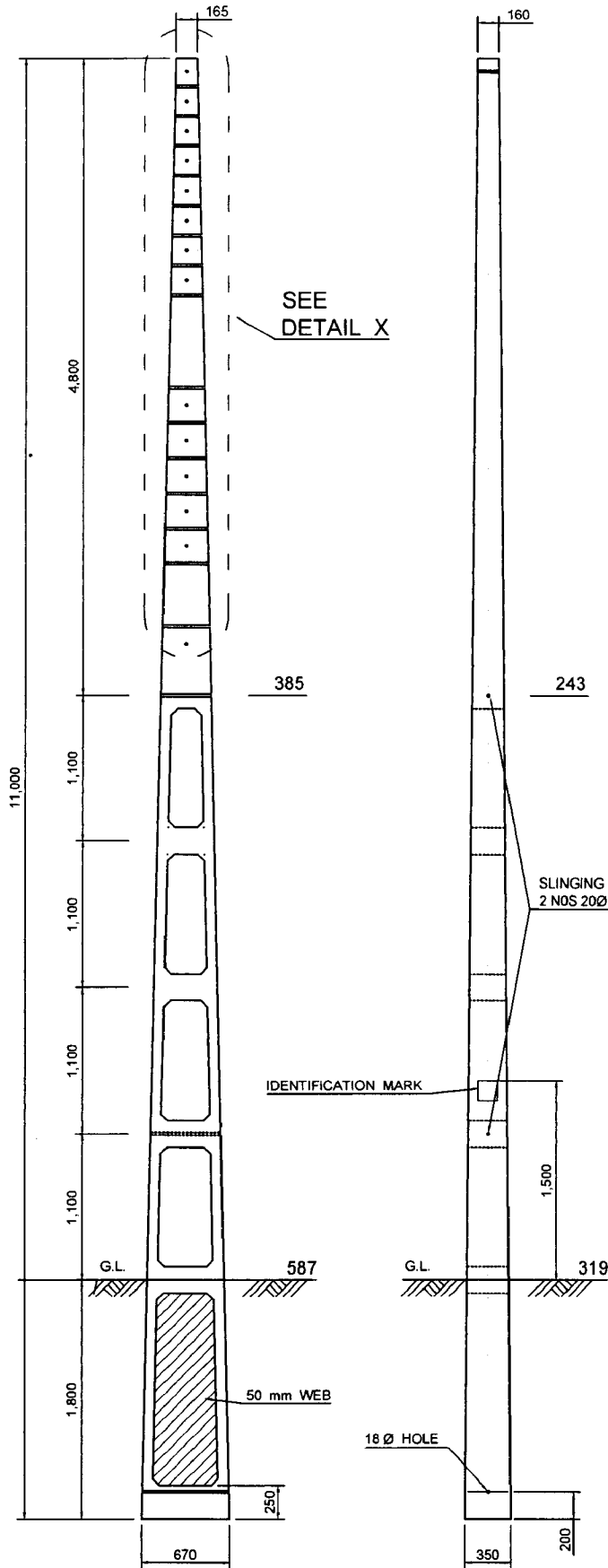

ELEVATION

ALL DIMENSIONS ARE IN MM.

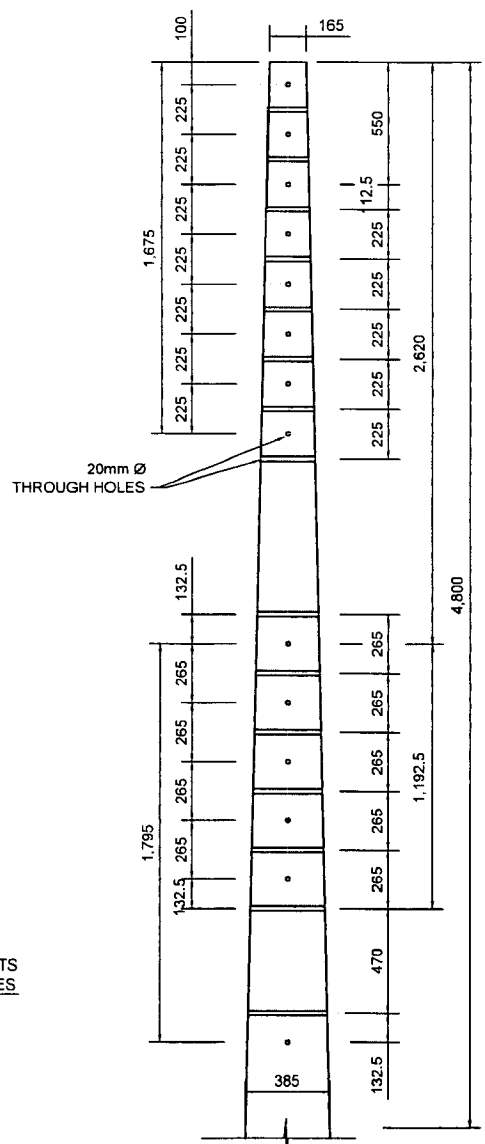

DETAIL X

NOTE

1. CONCRETE TO BE GRADE C40 (NOMINL AGG. SIZE = 15 mm)
2. PRE STRESSING STEEL TO BE Ø 5 mm HIGH TENSILE STEEL WIRES WITH MIN. 32 KN CHARACTERISTIC.
3. SECONDARY STEEL TO BE 10 mm. TOR STEEL WITH MIN. 450 N/mm² CHARACTERISTIC STRENGTH.
4. STIRRUPS & WEB REINFORCEMENT TO BE MILD STEEL HAVING MINIMUM 250 N/mm² CHARACTERISTIC STRENGTH.
5. MIN. COVER TO ALL STEEL 20 mm
6. MIN. SPACING BETWEEN SECONDARY STEEL TO BE 25 mm. MIN. SPACING BETWEEN H.T. STEEL TO BE 20 mm.
7. H.T. WIRES DE BONDED (1/2 No. EACH FACE)
2 Nos. FOR THE TOP 1500
2 Nos. FOR THE TOP 1000
8. 10 Nos. Ø 6mm MILD STEEL STIRRUPS AT 150 CTRS FROM TOP OF POLE
9. 4 Nos. 5mm UNITENSIONED H.T. WIRES UP TO 6.8 M FROM BOTTOM END
9. ALL HOLES Ø20 mm UNLESS SPECIFIED OTHERWISE

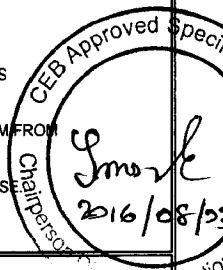

 <p>CEYLON ELECTRICITY BOARD</p>	DISTRIBUTION STANDARDS & SPECIFICATION		SCALE : NOT TO SCALE
	11.0 METER 850 KG PRE-STRESSED POLE		DRAWN : LALANI
	DESIGNED BY	APPROVED BY	DATE : May, 2016
DISTRIBUTION COORDINATION BRANCH	EE (DC)	CHAIRMAN, SPECIFICATION COMMITTEE	DRG. NO : DS&S/2016/140-2F
			CAD NO :

Annex- B

SCHEDULE OF GUARANTEED TECHNICAL PARTICULARS

(Following Information shall be furnished with the offer)

1.	Name of manufacturer	
2.	Country of manufacturer	
3.	Applicable standards	
4.	Applicable conductor particulars	
	(a) Nominal cross section area of the phase conductor	mm ²
	(b) Nominal cross section area of the messenger wire	mm ²
5.	Material	
	(a) Suspension small angle assembly	
	i. Triangular suspension hardware	
	ii. Suspension clamp with movable connecting link	
	iii. Clamping bolt	
	(b) Large Angle/Dead End assembly	
	i. Tension bracket	
	ii. Dead end clamp	
6.	Minimum Breaking Load of:	
	(a) Suspension clamp	kN
	(b) Triangular suspension bracket	kN
	(c) Tension Clamp	kN
	(d) Tension bracket	kN
	(e) Large angle assembly	kN
	(f) Insulated cable joints	kN
7.	Voltage withstand capability of;	
	(a) Suspension clamp	kV
	(b) Tension Clamp	kV
8.	Characteristics of termination & jointing components	
	(a) Voltage rating applicable	kV
	(b) Specific creepage distance of the terminations	mm
	(c) Maximum current carrying capacity of joints	A
	(d) Maximum current carrying capacity of terminations	A
	(e) Special tools required for joints	
	(f) Special tools required for terminations	
9.	Whether certified copy of ISO 9001:2008 in accordance with clause 6.0 furnished with the offer?	Yes/No

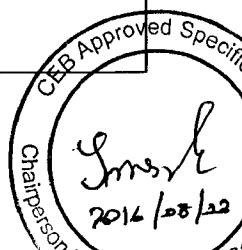

10.	Whether the entire Type Test certificates in accordance with clause 8.1 furnished with the offer?	Yes/No	
11	Whether the information as per clause 9.0 supplied with the offer?	Yes/No	

.....
Signature of the Manufacturer and seal

.....
Date

I/We certify that the above data are true and correct

.....
Signature of the Bidder and seal

.....
Date



Annex-C

Non-Compliance Schedule

On this schedule the bidder shall provide a list of non-compliances with this specification, documenting the effects that such non-compliance is likely to have on the equipment life and operating characteristics. Each non-compliance shall be referred to the relevant specification clause.

Clause No.	Non-Compliance

.....
Signature of the Manufacturer/bidder and seal

.....
Date

