

PM

GUIDE FOR GRID
INTERCONNECTION OF
EMBEDDED GENERATORS

Part 2:
Protection and Operation of
Grid Interconnection

December 2000



Ceylon Electricity Board
P O Box 540
Colombo
Sri Lanka

CONTENTS OF PART 1 OF THE GUIDE (SEPARATELY BOUND)

Glossary, Definitions and Abbreviations

1. Scope of the Guide

2. Introduction to the Guide

- 2.1 Mandatory Requirement
- 2.2 Guidelines for Design, Testing and Operation
- 2.3 Capacity and Interconnection Voltage
- 2.4 Higher Capacities, Voltages and Upgrades
- 2.5 CEB's Discretion to Waive the Requirements
- 2.6 Requirements Limited to Embedded Generators
- 2.7 Designated Officers

3. Embedded Generation

- 3.1 What is Embedded Generation?
- 3.2 Embedded Generators in a Distribution Network
- 3.3 Islanded Operation
- 3.4 Grid System Security
- 3.5 Availability of Capacity

4. Context

- 4.1 Grid Capacity, Embedded Generation and System Load
- 4.2 System Reliability and Stability
- 4.3 Future Capacity, Load and Embedded Generators
- 4.4 Types of Connection
 - 4.4.1 Embedded Generators with a Substantial Captive Local Load
 - 4.4.2 Embedded Generators with Minimal Captive Local Load
 - 4.4.3 Separate Agreement Required to Import Energy
- 4.5 Capacities
- 4.6 Locations
- 4.7 Distribution System Arrangement

5. Procedural Issues

- 5.1 Initial Application
 - 5.1.1 Information to be Provided
 - 5.1.2 Processing Duration
- 5.2 Site Reference Number
- 5.3 Letter of Intent
 - 5.3.1 Period of Validity
 - 5.3.2 Reservation of the Source
 - 5.3.3 Reservation of Network Capacity
 - 5.3.4 Point of Interconnection
- 5.4 Exchange of information about the Interconnection
 - 5.4.1 From Generating Company to the CEB
 - 5.4.2 From CEB to the Generating Company
- 5.5 The Power Purchase Agreement
- 5.6 Operational Information to be Provided
- 5.7 Costs of Interconnection
 - 5.7.1 Direct Costs of Interconnection and Studies

- 5.7.2 Costs of Network-side Modifications
- 5.8 Metering
 - 5.8.1 Metering to be at the Point of Supply
 - 5.8.2 Metering Equipment Costs
- 6. Implementation of the Guide
 - 6.1 CEB to Implement the Guide
 - 6.2 Revisions
- 7. Effective Date
 - 7.1 Effective Date
 - 7.2 Generators Under Construction by the Effective Date
 - 7.3 Generators in Operation by the Effective Date
 - 7.4 Final Date for Compliance
- 8. Interconnection Certificate
 - 8.1 CEB to Issue the Certificate
 - 8.2 Form of Interconnection Certificate
 - 8.3 Validity
 - 8.4 Designated Officers
 - 8.5 Testing and Acceptance Procedure
 - 8.6 Costs and Fees of Interconnection Tests and Certificate
- 9. Testing and Acceptance Procedures
 - 9.1 General
 - 9.2 Responsibilities and Witnessing
 - 9.3 Test Procedures
 - 9.4 Test Intervals
 - 9.5 Records
- Annex 1 Form of Initial Application
- Annex 2 Form of Letter of Intent
- Annex 3 Forms of Information to be Exchanged
- Annex 4 Form of Interconnection Certificate
- Annex 5 Form of Test Record
- Acknowledgements
- Bibliography

FIGURES IN PART 1 OF THE GUIDE

- Figure 1- Typical Distribution System Arrangement with Embedded Generators
- Figure 2- Procedural Flowchart of Embedded Generator Connection Process
- Figure 3- Typical Single Line Drawing

CONTENTS OF PART 2 OF THE GUIDE

Glossary, Definitions and Abbreviations	6
1. Studies and Information to be Exchanged	11
1.1 Stability	11
1.2 Fault Level	12
1.3 Protection	12
1.4 Voltage Levels	13
1.4.1 Interconnection Voltage	13
1.4.2 Voltage Flicker	13
1.4.3 Voltage Rise	14
1.4.4 Studies on Voltage Flicker and Voltage Rise	14
1.5 Earthing	14
1.6 Load Flow	14
2. Fault Level	15
2.1 General	15
2.2 Fault Level Information	15
2.3 Fault Level Calculation	15
2.4 Fault Level Reduction and Mitigation	17
3. Voltage Regulation	18
3.1 General	18
3.2 Voltage Limits	18
3.3 Power Factor Requirements	19
4. Earthing of Electricity Networks and Embedded Generators	20
4.1 General	20
4.2 CEB Electricity Supply Networks	20
4.3 Compatibility of Network and Generator Earthing	21
4.4 Generator Parallel Earthing	21
4.5 Interconnection of CEB and Generator Earth Systems	23
4.6 Design of Earth Systems	25
5. Synchronisation of Generators	26
5.1 General	26
5.2 Voltage Fluctuation	26
5.3 Synchronous Generators	26
5.4 Asynchronous Generators	26
5.5 Other Types of Generators	27
5.6 Synchronising Check relay	27
6. Islanded Operation	28
6.1 General	28
6.2 Hazards of Islanding	29
6.2.1 Unearthed Operation of the Distribution System	29
6.2.2 Lower Fault Levels	30
6.2.3 Out of synchronisation reclosure	30
6.2.4 Voltage Levels	30
6.2.5 Quality of Supply	31
6.2.6 Risk to Maintenance Personnel	31
6.3 Common Cause Tripping	31

6.3.1 General	31
6.3.2 Risks to the Network	31
6.3.3 Risks to the Generator	32
6.4 Sources of Common Cause Tripping of Generators	32
6.4.1 Loss of Mains Relays	32
6.4.2 Voltage Relays	32
6.4.3 Frequency Relays	33
6.4.4 Local Generator Instability	33
7. Islanding Detection and Protection	34
7.1 General	34
7.2 Islanding Detection Systems and Settings	35
7.2.1 General	35
7.2.2 Over and Under Voltage	35
7.2.3 Over and Under Frequency	35
7.2.4 Rate of Change of Frequency	36
7.2.5 Voltage Vector Shift	36
7.2.6 Reverse VARs	38
7.2.7 Intertripping	38
7.2.8 Fault Thrower	39
7.2.9 Restoration	39
7.2.10 Future Developments	39
7.3 Islanding Network Protection	40
7.3.1 General	40
7.3.2 Inhibiting of Reclose Devices	40
7.3.3 Neutral Voltage Displacement (NVD) Protection	41
8. Implementation of Islanding Protection	43
8.1 General	43
8.2 Interconnection Protection Requirements	43
8.2.1 Case 1	45
8.2.2 Case 2	47
8.2.3 Case 3	49
8.2.4 Case 4	51
8.2.5 Case 5	53
8.2.6 Self Commutated Static Inverters	54
9. Surge Protection	55
9.1 General	55
9.2 Location of the Arrester	55
9.3 Earthing	56
9.4 Selection of the Lightning Arrester	56
9.5 Generators Directly Connected to LV Overhead Lines	56
10. Harmonics	58
11. Operational Procedures and Requirements	59
11.1 Means of Isolation	59
11.2 Earthing Facilities for Maintenance	59
12. Safety Aspects	60

Annex 1	Explanatory Notes on Earthing
Annex 2	Explanatory Notes on Islanding Detection and Protection
Annex 3	Explanatory Notes on Neutral Voltage Displacement
Annex 4	Typical AVR model
Acknowledgements	
Bibliography	

LIST OF FIGURES IN PART 2

Figure 1-	Interconnection Protection Arrangement for Case 1	46
Figure 2-	Interconnection Protection Arrangement for Case 2	48
Figure 3-	Interconnection Protection Arrangement for Case 3	51
Figure 4-	Interconnection Protection Arrangement for Case 4	53
Figure 5-	Typical Earthing Options for Networks with Embedded Generators	A1:20
Figure 6-	Connection of Earthing Systems Associated with LV/33kV Generators	A1:21
Figure 7-	Network Voltage During an Earth Fault	A3:5
Figure 8-	Neutral Voltage Displacement Protection using a 3-phase, 5-limb Voltage Transformer with an Open Delta Winding	A3.6
Figure 9-	Example of Typical AVR Modelling Information	A4:2

PREAMBLE

Embedded Generators have been connected to the Ceylon Electricity Board (CEB) system under Power Purchase Agreements since 1997.

The Power Purchase Agreements between Embedded Generators and CEB are covered by the Electricity Act of Sri Lanka, and other Regulations.

This Guide covers the requirements to be fulfilled by the Interconnection between the Embedded Generator and the CEB system.

The Guide is in Two Parts.

Part 1 of the Guide (separately bound) explains the procedure to be followed in making an application to develop an embedded generator, evaluation by CEB, and the process of conducting acceptance tests on the Interconnection.

Part 2 of the Guide explains the studies to be conducted by CEB to ensure the interconnection is safe, and provides guidelines for effective design and operation of the interconnection.

This Guide does not replace or supersede any of the requirements specified in the Electricity Act, Ceylon Electricity Board Act, Electricity Regulations or Power Purchase Agreements.

ASSOCIATED DOCUMENTS AND PUBLICATIONS

1. Guidelines on Private Sector Participation in Small Hydro Power Development, Ceylon Electricity Board (current issue).
2. Standardised Agreement for Purchase of Energy, Ceylon Electricity Board (current issue).

This Guide is based on the requirements of Ceylon Electricity Board (CEB), Sri Lanka, and the conditions and constraints under which the CEB system operates. The primary intention of this Guide is to establish procedures and equipment to protect CEB personnel, equipment and the system from any harmful effects arising out of the interconnection and operation of Embedded Generators

Therefore, it should not be assumed that the guidelines provided would satisfy all the protection requirements of the Embedded Generators. No responsibility can be accepted for any loss or damage sustained as a result of using or relying on this Guide.

GLOSSARY, DEFINITIONS AND ABBREVIATIONS

AVC: Automatic Voltage Controller

AVR: Automatic Voltage Regulator

CEB: Ceylon Electricity Board, a body Corporate duly constituted by Act No. 17 of 1969 of the Democratic, Socialist Republic of Sri Lanka.

Captive Generation: Generating plant available at CEB customer facilities, but not connected in parallel with the CEB network.

Captive Line Load: Load, up to the 1st point of automatic isolation, which is (or may be) supplied by an Embedded Generator, excluding Captive Local Load.

Captive Local Load: Load within the Embedded Generator premises including generator auxiliaries

Captive Load: The sum of Captive Line Load and Captive Local Load

Common Mode (or Cause) Tripping: Automatic removal of two or more generating plant from the system owing to a cause that is common to both or all the generators.

Combined Heat and Power (CHP): A plant that generates electricity and supplies thermal energy, typically steam, to an industrial or other heating requirement.

EF: Earth Fault (protection)

Embedded Generator: A single generator, or a group of generators, connected to the distribution network of the CEB, at voltages between 400 V and 33 kV.

Export of Electrical Energy: Supply of Electrical Energy by a Generator to the CEB system.

Generating Company: A company, group or individual who plan to connect or has already connected an Embedded Generator to the CEB distribution network

Grid Interconnection: A link between CEB Electricity system and Embedded Generator's Electricity System, made for the purpose of Exporting or Importing Electrical Energy.

Grid Substation: A CEB substation where electrical energy at 220 kV or 132 kV is transformed into 33 kV.

Highest (Lowest) Voltage of a System: The highest (lowest) value of operating voltage which occurs under normal operating conditions at any time and at any point in the system.

HV: High voltage, exceeding 1000 V between conductors and 600 V between conductors and earth.

Import of Electrical Energy: Receipt of Electrical Energy by the Embedded Generator from the CEB system.

Interconnection Certificate: A Certificate issued by CEB to an Embedded Generator, after testing the interconnection.

Interconnection Voltage: The nominal voltage at which the grid interconnection is made.

Initial Application: The first application by an individual or Company aspiring to develop an Embedded Generator.

Islanding: The process whereby a power system is separated into two or more parts, with generators supplying loads connected to some of the separated systems.

Islanded Operation: The situation that arises when a part of the electrical system is disconnected from the main grid and is energised by one or more generators connected to it

Letter of Intent (LOI): Issued by CEB to a Generating Company to signify CEB's intent to purchase power from a Generating Company at a particular location

LOM: Loss of mains (protection)

LV: Low voltage, not exceeding 1000 V between conductors and 600 V between conductors and earth.

Neutral Point Displacement Voltage: The voltage between the real or virtual neutral point and the earth.

NVD: Neutral Voltage Displacement. A technique to measure the displacement of the neutral voltage with respect to earth.

Nominal Voltage: A suitable approximate value of voltage used to designate or identify a System.

OC: Over-current (protection)

OF: Over-frequency (protection)

Operating Voltage: The value of the voltage under normal conditions at a given instant and at a given point in the system.

OV: Over-voltage (protection)

Point of Common Coupling (PCC): The location of the connection between the CEB network and the Embedded Generator, beyond which other customer loads may be connected on the CEB side. The PCC may be separate from the Point of Supply where a line is dedicated to the connection of an Embedded Generator.

Point of Supply (POS): The location of the connection between the CEB network and the Embedded Generator.

Power Purchase Agreement (PPA): An agreement between the CEB and the Generating Company for the purchase of electricity by the CEB.

ROCOF: Rate-of-change of Frequency (protection)

RP: Reverse Power (protection)

SBEF: Standby Earth Fault (protection)

Spinning Reserve: The difference between the total available capacity of all generating sets already coupled to the system and their total actual loading.

Step Voltage: The difference in surface potential experienced by a person bridging a distance of 1 m with his feet without contacting any other grounded structure

Touch Voltage: The potential difference between the ground potential rise (GPR) and the surface potential at the point where a person is standing where at the same time having his hands in contact with a grounded structure. GPR defined as the maximum voltage that a station grounding grid may attain relative to a distant grounding point assumed to be at the potential of remote earth. The touch voltage could be from hand to hand also.

Transferred Voltage: This is a special case of the touch voltage where the voltage is transferred into or out of the station by a conductor grounded at a remote point or at the station ground, respectively.

TNS system of Earthing: In this earthing system, the supplier provides separate Neutral and Protective conductors throughout the system. The Protective Conductor is connected to the neutral of the source. All exposed conductive parts of a consumer's installation are connected to the Protective Conductor provided by the supplier via the main earthing terminal of the consumer's installation.

TT System of Earthing: An earthing system where all exposed conductive parts of an installation are connected to an earth electrode provided by the consumer which is electrically independent of the Source earth.

UV: Under-voltage (protection)

UF: Under-frequency (protection)

Voltage Level: One of the Nominal Voltage values used in a given system.

VS: Vector Shift (protection)

1. STUDIES AND INFORMATION TO BE EXCHANGED

CEB may conduct the studies listed in the following subsections before authorising the interconnection of an Embedded Generator. These studies will be conducted within the period of validity of the LOI, after the Generating Company provides information shown in Annex 3 in Part 1 of the Guide, and when the CEB is satisfied that the detailed designs for the Embedded Generator are in progress.

CEB may charge a fee to conduct these studies and to provide the information, as outlined in Sub-section 5.7.1 of Part 1 of the Guide.

1.1 Stability

CEB may analyse the effect of implementing the additional generation on the stability of the CEB's system.

Local stability will be studied when the additional Embedded Generation has a capacity greater than 5 MW or makes the total generation capacity on a single distribution line greater than 5 MW.

Information required for a stability study should be submitted by the Generating Company, irrespective of the generator capacity.

This may be waived by the CEB for small Embedded Generators, typically less than 1 MW. However, CEB reserves the right to request this information at a later date.

The Generating Company shall provide a model of the Automatic Voltage Regulator (AVR) of the Embedded Generator, when the proposed capacity is over 5 MW. The Form of the AVR Model is shown in Annex 4.

The Generating Company shall provide a model of the speed Governor of the Embedded Generator, when the proposed capacity is over 5 MW. Important information such as the inertia constant and governor characteristics shall also be provided

1.2 Fault Level

The Generating Company shall provide information on the three phase symmetrical sub-transient fault contribution at the Point of Supply, when the Fault Level Information shown in Annex 3 of Part 1 of the Guide is provided to CEB.

The cumulative effect of the Embedded Generator shall be assessed by the CEB.

A study will be conducted when the cumulative fault level on a distribution system reaches 90% of the rating of the associated distribution switchgear.

The study may lead to the requirement for more detailed information from the Generating Company for detailed analysis.

1.3 Protection

A study will be required to assess the effect on the distribution system protection ratings and settings if any of the following situations occur.

- When the maximum short circuit current that can be produced by a single Embedded Generator (meaning a site consisting of one or several generating units, interconnected to the CEB network through a single Point of Supply) is greater than 20% of the maximum short circuit current of the distribution system.
- When the cumulative maximum short circuit current that can be produced on a distribution line (from a collection of generating stations) is greater than 30% of the maximum short circuit current of the distribution system.
- When there will be net export of power from the 33 kV distribution system into the 132 kV system. This may have a particular impact on 132kV distance protection and also on directional overcurrent protection at the grid substation.

1.4 Voltage Levels

1.4.1 Interconnection Voltage

The Voltage at the Point of Supply from the Embedded Generator to the CEB network shall be determined as follows:

Embedded Generators with installed generating capacity up to and including 250 kVA, shall be interconnected at the LV distribution voltage level, if the nominal output voltage of the generator is 400 V line to line, 3-phase or 230 V line to neutral, 3-phase.

Embedded Generators with an installed generating capacity exceeding 1000 kVA shall be interconnected at the high voltage level. The nominal high voltages in the CEB system are 11 kV and 33 kV.

For installed capacity in the range above 250 kVA to 1000 kVA, the interconnection voltage will be determined by CEB on a case-by-case basis, depending on the capacity of the transformer substation.

The Point of Supply and its nominal voltage shall be defined by CEB at the time of issuing the LOI.

After any required studies, CEB shall also provide the applicable normal operating voltage, maximum normal voltage and maximum permitted voltage at the POS.

CEB shall provide information on the power factor limits at the POS.

If a generator is directly (or closely) connected to a grid sub-station, CEB shall also specify the power factor for the generator.

1.4.2 Voltage Flicker

The generator should not cause voltage flicker at the POS which exceeds that defined in CENLEC Standard BS EN 50160

1.4.3 Voltage Rise

The voltage rise at the POS due to the generation must be within operational limits.

The target bandwidth for voltage on the 33 kV busbar of a grid sub-station is 3%.

The target voltage on the 33 kV busbar of the grid sub-station is 33 kV.

1.4.4 Studies on Voltage Flicker and Voltage Rise

A two-stage approach will be required in conducting these studies:

Stage I: Exclude load connections to distribution lines and grid transformers

Stage II: Include load connections to distribution lines and grid transformers

The Stage II study will be required when the Stage I study indicates a potential problem.

1.5 Earthing

The Generating Company shall provide information about the proposed earthing arrangement to the CEB. Guidance on earthing system are given in Section 4 and Annex 1.

1.6 Load Flow

Power supplied by the generator may cause thermal overloading of the CEB network components, and studies may be required on:

Distribution lines: consider the effects of the cumulative generation capacity connected to the line

Grid sub-station transformer(s): consider the effects of the cumulative generation capacity connected to the sub-station.

132 kV/220 kV lines: consider the effects of the cumulative generation capacity connected to the line from multiple sub-stations, particularly the effect of a closed ring outage.

2. FAULT LEVEL

2.1 General

Fault levels in a distribution network must be maintained within design limits. Ratings of switchgear shall be in accordance with the declared design fault level for the maintenance of system protection performance.

The connection of a generator to a distribution system will increase the fault level on the network when both the generator and grid are connected, and the effect of this change should be considered.

Fault levels in rural distribution networks tend to be relatively low and the contribution of smaller embedded generators are not normally a problem. However, there may be protection problems such as under-reaching of 132kV distance protection or possibly on 33kV overcurrent, protection when the Embedded Generator contribution is included.

2.2 Fault Level Information

CEB shall provide the design fault levels to the Generating Company on fault levels of the system at the Point of Supply.

The Generating Company shall provide fault level contribution of generator(s) at the Point of Supply. The Generating Company shall provide tolerances on the fault level data provided.

The information requirements are specified in pro-formas shown in Annex 3 of Part 1.

Induction Generators

For induction machines, the data set is not standard and, therefore, data requirements for induction generators should be agreed between the CEB and the Generation Company.

2.3 Fault Level Calculation

CEB shall be responsible for monitoring fault levels on the distribution network and performing detailed assessments as appropriate to ensure that fault limits are not exceeded.

The calculation of fault current levels should include consideration of the main network transformer sources, rotating plant and static converter drives which may transfer energy into the network.

Fault calculations shall be based on methods defined in the IEC 909. The fault types are described below in order to provide an outline, and a common understanding of the principle quantities.

Make fault level

This is the peak asymmetrical fault current after the initial fault. The following parameters determine this fault level: system voltage, rotating machine sub-transient reactance and time constant, grid transformer source impedance, network impedance and overall X/R ratio. The calculation is based on the most onerous source impedance and network configuration to derive a maximum value. In networks with high X/R ratio, it is typically about $1.8 \times \sqrt{2}$ times the initial symmetrical fault level and is often the main limiting factor.

Break fault level

This is the total fault current at the instant of circuit breaker fault interruption. The elapsed time from initial fault is dependent on the speed of relay and breaker operation, and is typically in the range of 4 to 8 cycles. The following parameters determine this fault level: system voltage, rotating machine transient reactance and time constant, grid transformer source impedance and network impedance. The calculation is based on the most onerous source impedance and network configuration to derive a maximum value. The decrement of generator fault contribution, particularly for asynchronous machines, is typically very significant during this period, and should be taken into account for detailed fault level assessments.

Steady-state fault contribution

This is the symmetrical fault current at a time after the complete decay of sub-transient and transient fault contribution from rotating machines. The steady-state contribution of synchronous machines is influenced by the AVR characteristic. However, for most purposes, this quantity would be used for minimum fault level only and, in this case, it would be normal to neglect all Embedded Generator contribution, and use the most onerous source and network conditions to derive a minimum value.

2.4 Fault Level Reduction and Mitigation

Where it has been identified that the connection of a new generator will lead to excessive fault currents, the contribution of the generator can be reduced by the use of additional impedance.

This may take the form of an isolating transformer, a reactor or additional length of circuits. An isolating transformer is preferred.

The use of short circuit current limiters based on the fuse and explosive link principle, as a way of mitigating the effect of increased fault currents, is not recommended. This is on the grounds that they are not fail safe and there is a lack of CEB experience and information on their reliability. This may be reviewed in the light of further development and experience.

Resonant links or future HTS, high temperature superconducting transformers are a possible, but costly, solution.

3. VOLTAGE REGULATION

3.1 General

Control of voltage on the distribution system is affected by the connection of embedded generation. The power being fed into the grid from the embedded generator will raise the voltage at the POS. This may be an acceptable support to local network voltage or it may cause the operational or statutory voltage limits of the local distribution system to be exceeded.

This voltage rise may be mitigated by the generator importing reactive power. The effectiveness of this is dependant upon the X/R ratio of the distribution system. For example, a cable feeder with a low X/R ratio would require a large proportion of imported reactive power to have a significant mitigating effect on the voltage rise at the POS.

The import of reactive power increases the current flow in the distribution network, leading to additional network losses and use of capacity.

The consumption of reactive power by a generator may reduce the capacity and efficiency of generating plant due to the current loadings in the generator stator windings.

The voltage rise at the POS may also be mitigated by a reduction in the upper limit of voltage at the grid substation. This can be achieved by reducing the bandwidth and/or the target voltage of the substation AVC. However, both options would require careful consideration: Reducing the AVC bandwidth would potentially increase the tap change operation frequency of the grid substation transformers, reducing the target voltage would potentially cause remote customers to experience voltage levels below statutory limits. CEB will give careful consideration to the optimisation of network voltage control, possibly using AVC with line drop compounding settings for voltage boost and power factor droop, to encourage the connection of embedded generation without compromising statutory obligations to existing customers

3.2 Voltage Limits

Having determined an optimum target voltage and limits for voltage at the grid substation, these limits shall be declared and be available to all prospective Generating Companies. See section 5 of Part 1 on information to be provided by the CEB.

Voltage at the Point of Common Coupling should be in accordance with the statutory limits.

Non-statutory limits may be agreeable between CEB and the generating company if no other customers are affected. For example, where the Point of Common Coupling is remote from the Point of Supply with a long line that only serves the generating site or with no direct connection of customers at the line voltage.

CEB reserves the right to review and revise any such non-statutory limits. The Generating Company shall bear the costs resulting from any such revisions.

3.3 Power Factor Requirements

The PPA shall specify a power factor for the connection – this will be typically unity but may be leading (importing reactive power), depending on voltage regulation issues. It should be noted that this specified value will be subject to the tolerance of the generator power factor control unit.

Payments for reactive power may be considered in the future, and are not covered in the Guide. This will require consideration of loss adjustments for active power export.

It may be desirable to operate generators in a voltage control mode to limit voltage rise on distribution circuits, with a likelihood of consequent reactive power imports. In this situation, the interaction of the generator voltage control systems will need to be considered when there is more than one generator connected to a distribution line.

Similarly, generator power output can be constrained to limit voltage rise under conditions of low feeder load. Again, the interaction of power or voltage constraint control systems where there is more than one generator needs careful consideration.

4. EARTHING OF ELECTRICITY NETWORKS AND EMBEDDED GENERATORS

4.1 General

Public electricity transmission and distribution networks are connected or referenced to earth as close to their energy source as possible. Earthing of networks and the non-current carrying metalwork of plant and equipment provides a pre-determined path for the flow of fault current to operate protective devices in the event of a single earth fault. While it is possible to detect earth faults in unearthed networks, protection discrimination and security in large systems is difficult if not impossible.

Disconnection of faulty equipment is important to prevent danger and reduce damage from long-term over-voltages. Such over-voltages may be caused by an inadvertent contact with a higher voltage system or when a transferred voltage rise occurs in lower voltage networks due to voltage rise of earth systems shared with other higher voltage networks.

The key reason for earthing any electrical system and the connected plant is to reduce the risk of electrical shock and prevent unnecessary damage. The design of earthing systems for substations and plant in electrical networks will achieve this in the most economical manner, and will be appropriate to the type of network and its protection policies. Safety requires co-ordination between fault current magnitude, the resulting voltages appearing in earth systems and speed of protection.

Note that the term HV is used for all voltages above 1000 V. to be consistent with the other sections of the Guide.

Informative Annex 1 provides additional details and explanation of requirements for earthing generators connected to the CEB electricity networks.

4.2 CEB Electricity Supply Networks

CEB electricity supply networks may be connected to earth at a single point or at two or more points. Multiple network earthing may exist at a single substation location or at different points in the network to facilitate interconnections and operational changes.

The methods used to earth the CEB distribution networks are as follows:

- Solid earthing of neutral points of all transformer windings connected to networks having an operating voltage of 132 kV or higher.
- Impedance earthing or arc suppression coil earthing of transformer secondary windings supplying networks having an operating voltage of 33 kV.
- Impedance or solid earthing of transformer secondary windings providing customer 11 kV supplies or supplying the CEB network with an operating voltage of 11 kV.
- Solid earthing of transformer secondary windings providing customer low voltage supplies or supplying LV networks.

4.3 Compatibility of Network and Generator Earthing

Arrangements should be agreed to earth the Embedded Generator's system in a manner compatible with the CEB supplies. Furthermore, appropriate generator protection is required to maintain safe conditions in the CEB network should its normal earth point become isolated or disconnected.

To accept additional points of network earthing such as generator parallel earthing, CEB will consider the following technical issues:

- Controlling magnitude of earth fault current
- Maintaining a predetermined path for earth fault current
- Detecting earth leakage current
- Limiting circulating currents at fundamental and harmonic frequencies
- Avoiding interference to communication systems
- When appropriate, maintaining the effectiveness of network earthing

4.4 Generator Parallel Earthing

Where a generator is connected to the CEB 33 kV and 11 kV supply networks and at risk of being islanded, the preferred method for safe operating conditions is for the generator to be earthed at the PCC to the CEB HV supplies.

Parallel earthing when operating in parallel with the CEB electricity supply network will simplify and generally provide safer generator connections. To allow this, CEB will consider the above technical issues.

While an earthed generator or earthed transformer neutral point will satisfy the basic requirements for safety, the detailed design of earthing of generators requires careful consideration.

Large generators, (larger than 1MW) may be earthed when operating in parallel with 11kV or 33kV networks. This will normally require a neutral earthing impedance of value to be agreed. Typically, this may be of the order 1 pu to ensure an adequate protection performance.

The decision regarding earthing of small generators when operating in parallel with public electricity networks will take account of the cost of providing the earthing facility. It is considered that generally, it will be uneconomic for generators smaller than 1MVA to provide parallel earthing facilities.

Use of a suitable transformer winding or the interlocking of switches and automatic earthing of the generator neutral only when the incoming mains are disconnected may be required to avoid parallel generator earthing. Where a generator is required to operate independently of the CEB supplies, it must have an earth electrode system, which should be bonded to the CEB earthing system or terminal, wherever this is available and practical. Alternatively where permitted, a generator may use a shared earth system.

The agreed method of earthing a generator should achieve minimum risk to generator plant, the supply network it is connected to and operating personnel.

CEB may decide that a generator must not have parallel neutral point earthing when operating in parallel with the CEB supplies. In this case, appropriate protection must ensure that an islanded generator is automatically disconnected.

If an islanded generator may continue to operate and supply Local Captive Loads and some Line Captive Loads,

- The generator/network connection point may be appropriately parallel-earthed while the generator operates.
- The network at the Point of Common Coupling may be automatically earthed if islanded.
- Appropriate devices such as Neutral Voltage Displacement protection may be provided to ensure safe conditions, and disconnect the generator if an earth fault occurs in the CEB system or the generator system.

Where a generator is connected to the CEB LV supply network away from a substation, the preferred method to ensure safe operating conditions and remove risk of damage if neutral conductors become open circuit, is for the generator to operate without a parallel neutral earth connection.

Protective devices must disconnect an islanded generator under this condition.

Where a generator is connected to the CEB LV supply network with an on-site substation and should the network be of TN-C type (having multiple earthed neutral conductors), the generator may operate with a parallel neutral earth connection.

The arrangement must ensure that the connection of the generator neutral point to the generator's earth system and the CEB earth system/terminal is substantial, solid, direct and clearly identified.

Regular checks on the earthing system must be conducted by the Generating Company.

4.5 Interconnection of CEB and Generator Earth Systems

Earthing an electricity supply network and a generator system requires the CEB and generator plant and electrical equipment to be connected to an earth system with appropriate earth electrodes.

Wherever networks operating with different voltages are in close proximity and resistance areas of their earth systems overlap, the overlapping earth systems should preferably be interconnected.

In small systems like a generator installation, this will generally achieve the lowest practical earth resistance value and will minimise voltage differences between adjacent plants with different operating voltages.

HV metered supplies to generator premises require a combined HV earth system. The HV earth terminal will include an earth connection to a CEB earth electrode system and possibly provide a metallic path to the point where the CEB HV network neutral point is earthed.

The generator will have to consider the possible effects of connecting generator system HV and LV earth systems and ensure safe operating conditions

LV supplies to generator premises from a dedicated, local CEB HV/LV

transformer normally will have independent HV and LV earth systems.

If combined, the rise of voltage and the transferred voltage to the LV neutral shall be within acceptable limits.

If independently earthed, the CEB LV earth terminal should preferably be connected to the Embedded Generator's earth system.

This will minimise the risk of damage to plant in the Embedded Generator's system.

The insulation of the supply transformer LV winding and terminals must be adequate to prevent danger from the rise of voltage on the HV earth system for an earth fault in the supplying substation.

The separation of the CEB HV and LV earth system and the generator earth system must be adequate to ensure that any overlap of the resistance areas of the two earth systems does not cause danger.

Where the CEB LV earth terminal/system may not be made available to the generator, the LV connection will be of the TT type, without a metallic path to the point the CEB LV network neutral point is earthed.

This will require the CEB and the generator earth system to have an appropriate earth loop resistance to ensure operation of protective devices. CEB shall provide to the Generating Company the impedance of the part of the earth loop that is within their control.

Where the separation of the CEB HV earth system and the generator earth system is not adequate to ensure that any overlap of the resistance areas of the earth systems is not sufficient to avoid danger, then all earth systems must be interconnected. Earth leakage protection shall be installed where the earth fault current is insufficient to operate over current protection.

The design of all earth systems must ensure that all touch and step voltages are within acceptable limits. Transferred voltages to Embedded Generator's plant must not create unacceptable touch and step voltages.

Precautions must be taken to prevent damage and remove danger arising from transferred voltages to and from external metallic services and metallic paths.

Typical earthing arrangements are shown in Annex 1.

4.6 Design of Earth Systems

Connection to the general mass of earth must be made using an earth system and ground electrodes of adequate thermal and current carrying capacity, and dimensioned to provide and maintain reasonably constant earth loop impedance, appropriate to the sensitivity of the installed protection devices. Connection of all plant to the earth system should ensure appropriate bonding and should also maintain touch and step voltages between and around earthed plant, inside and outside of buildings, within acceptable limits.

A CEB HV earth facility may not be effectively connected to local ground and may be subject to significant voltage rise above the potential of the general mass of earth. This may occur when earth leakage current flows for a local earth fault or a fault elsewhere in the supply network or in a higher voltage supply network.

Wherever an earth terminal is available from the CEB, this should be connected to the generator earth system to ensure the lowest possible impedance return path for earth leakage currents to the point the supply network is earthed.

This will minimise voltage rise, reduce stress on insulation and normally will be adequate to operate the Embedded Generator's protective devices.

Control of resulting transferred voltages to generator premises will be achieved by the design of the Embedded Generator earthing system and bonding of exposed metalwork on plant and equipment.

In certain cases, CEB may require the location to be classified appropriately for insertion of barrier facilities and safe isolation facilities in external metallic services, such as telecommunications with metallic wires.

Safety requires compliance with Earthing Standards and prompt detection and isolation of earth leakage currents. The design of an earth system must ensure that touch and step voltages do not exceed voltage limits in the relevant CEB documents or Standards appropriate to the disconnection times.

5. SYNCHRONISATION OF GENERATORS

5.1 General

Synchronisation means the minimisation of the difference in magnitude, frequency and phase angle between the corresponding phases of the generator output and the grid supply prior to the connection of the two supplies.

Synchronisation can be achieved either manually or automatically, the latter being preferable. It is very unlikely that new installations will include only manual synchronisation. If manual synchronisation is suggested for a particular reason, its safe and reliable operation should be seriously considered and implemented carefully.

5.2 Voltage Fluctuation

During Synchronisation of a single generator, the induced voltage fluctuation on the grid should not normally exceed 3% at the Point of Common Coupling, and should also meet the requirements of voltage step and flicker given in Section 1.

5.3 Synchronous Generators

Before a synchronous generator can be connected to the grid, the generator must be run up unconnected and its speed adjusted to synchronise the generator output with the grid supply.

The voltage difference between the generator output and the grid supply should also be minimised. It is usual for the unconnected generator voltage to be set a few volts above the typical grid voltage.

Automatic synchronisation is usually achieved using a control system that incorporates control of the generating unit field and a governor or an electronic load control system.

5.4 Asynchronous Generators

Asynchronous generators normally require special measures to minimise the inrush current taken by the generator from the grid at the time of connection in order to meet the voltage fluctuation requirements of Section 11.

Suitable equipment and procedures may include:

- Electronic soft-start equipment
- Resistance starter
- Mechanically driving the generator up to near synchronous speed prior to connection.

5.5 Other Types of Generators

Other types of generators, which will include static inverters will need to have their output synchronised with the grid before or during grid connection. The transient characteristics of the connection shall be submitted to CEB.

5.6 Synchronising Check relay

A synchronising check relay must be used to inhibit the operation of the generator connection breaker or contactor. This relay will prevent connection of the generator to the grid when the two supplies are outside pre-set limits. This can be achieved using an electrical interlock.

Typical relay settings will be:

- $\pm 20^\circ$ of phase angle
- maximum difference in voltage of supplies of 7% of the same nominal voltage
- maximum slip frequency 0.44%

A time delay, typically 0.5 to 2 seconds, on the operation of the relay is commonly used to ensure the slip frequency is within limits.

Synchronising check relays may operate on a single or all three phases of the supplies. A single phase relay will not be able to check for phase rotation of the two supplies. If a single phase relay is used, then the phase rotation of the two supplies must be checked prior to first connection and following any maintenance operations that involved disconnection of any power cabling in the system.

6. ISLANDED OPERATION

6.1 General

In the context of embedded generation, an islanded network will typically comprise of:

- i) A single feeder or feeder section following a trip of the source circuit breaker or auto recloser.
- ii) A primary network or bus-section following a trip of the incoming circuit breaker(s).

Embedded generation and islanding are defined in Section 3 of Part 1.

It has been established that prolonged islanding is not acceptable, and hence protection is required to detect the condition and trip the generation within an acceptable time-frame.

In general, in an islanded group, there will not be a stable balance between load and generation resource. However, it is possible, in a few situations, that the generator and prime mover controls can establish a new equilibrium between generator(s) and load in an islanded group.

Protection to prevent islanding is required to detect an islanded situation and disconnect the generator from the distribution line.

There will also be a requirement for overcurrent and other types of generator protection, which are not specified in this Guide because such issues have no significant implications on the CEB system.

The sequence of conditions prior to and during islanding are:

Pre-islanded condition

The active and reactive power outputs of the generator are exported to the grid. The grid voltage and frequency are controlled by the grid and therefore stable conditions of voltage and frequency are achieved.

Initiating cause of islanding

There are many possible causes of islanding but they fall into two categories: fault or operational.

In the case of an operational cause such as under-frequency tripping, the circuit does not see significant initiating event.

Instant of islanding

At the instant that islanding occurs, there is an instantaneous change in the power flows of the islanding circuit and outputs of generators connected.

Island operation

For steady-state conditions to continue, the islanded electrical generation must equal the electrical load (neglecting electrical storage which is minimal). Since the probability of pre-islanded generation and load being equal is extremely unlikely, then the power imbalance must cause an acceleration or deceleration of the rotating plant in the islanded network and a resulting drift in frequency.

6.2 Hazards of Islanding

The potential hazards presented by operating a generator in an islanded situation are:

- Unearthed operation of the distribution system
- Lower fault levels
- Out of synchronisation reclosure
- Voltage levels
- Quality of supply
- Risk to maintenance personnel

6.2.1 Unearthed Operation of the Distribution System

It is usual for distribution line systems to be earthed at the grid sub station only, with an HV delta unearthed arrangement at the generator connection. This will always be the case where multiple earthing is not allowed, as is the case in Sri Lanka at the time of writing.

When part of a distribution network is disconnected from the grid sub station earth point, the unearthed system will be energised by embedded generators unless the generators are disconnected by islanding protection. The line to earth voltages of the three phases may then drift, or in the case of a line to earth fault, will be forced to shift. One phase will be referenced to earth causing the other phases to have a phase to earth voltage equal to the nominal phase to phase voltage. In this case, the normal design voltage limits for insulation and other equipment may be exceeded. This may cause damage or cause a hazard.

This situation can be detected using a Neutral Voltage Displacement relay, see Section 7 and Annex 3.

6.2.2 Lower Fault Levels

The fault level of an islanded system is likely to be lower than the minimum fault level of the grid sub-station during normal operation. This means that the settings of protection relays may be inadequate to protect the islanded network.

Details on the consideration of a change in fault levels and its effects are given in Section 10.

6.2.3 Out of synchronisation reclosure

In the period following the initiation of islanding, a phase difference arises between the grid and islanded side of the isolating circuit breaker or recloser. The grid and islanded network are said to be 'out of synchronism'. If the circuit breaker or recloser recloses before the generator is disconnected, then a severe surge of current may flow between the grid and the generator, causing severe voltage disturbances. The event can cause severe mechanical shock to the generator and prime mover, and there is risk of damage to the generator and equipment on the electrical system.

Out of synchronisation connection may be avoided by the use of dead line check or synch check facilities of the grid sub-station breakers. See Section 7.

6.2.4 Voltage Levels

The operation of a generator supplying a distribution feeder in an islanded situation may cause the system voltage levels to be outside normal operating or statutory limits.

The voltage will be determined by the output of the embedded generators which are primarily designed for connection to the grid and may be operating in power factor control mode with little control of output voltage.

The generator voltage protection limits of nominal $\pm 10\%$ may not protect consumers from voltage excursions substantially outside statutory limits but will limit the duration for compliance with BS EN 50160.

6.2.5 Quality of Supply

The islanded network will have a significantly lower fault level. This is likely to increase the voltage fluctuations during the period of islanding, caused by consumer electrical equipment.

6.2.6 Risk to Maintenance Personnel

The connection of a generator to a distribution line that has been disconnected from the grid for the purposes of maintenance or repair may cause harm to personnel through the energisation of a line that is expected to be dead.

All lines must be considered as possibly energised from remote sources and a distribution line that has been disconnected for maintenance or repair should have temporary earthing applied to the line before any work is undertaken. This would be part of normal procedures.

6.3 Common Cause Tripping

6.3.1 General

Common Cause (or Common Mode) tripping is where an event which causes a grid disturbance leads to the tripping of several generators, some of which may be on separate distribution lines from the one where the fault occurred.

6.3.2 Risks to the Network

Studies by the CEB, and experience from other countries, indicates that in Sri Lanka the risks to the grid network of the loss of generation can be classified as:

- Loss of a single generator or site with a maximum generation capacity of less than 10MW should have no significant effect on grid network if the connection meets voltage step requirements.
- Loss of multiple generators or sites with a maximum generation capacity totalling between 10 MW and 50MW will cause local voltage disturbances and possible instability of other generating plants.
- Loss of multiple generators with a maximum generation capacity totalling between 50MW and 100MW will cause significant grid frequency dip and possible under-frequency tripping of feeders. Under low demand conditions, it may also trigger a total failure of the CEB grid.
- Loss of multiple generators with a maximum generation capacity totalling greater than 100MW is likely to cause grid instability resulting in possible total failure of CEB grid.

Note that the levels of generation defined here are subject to change as the grid generation and loads change in the future.

The loss of a single generator in the scope of the Guide is not significant for the operation, stability or security of the grid. However, common cause tripping of many generators may have serious consequences for the CEB grid.

Frequent spurious tripping of generation can also have a significant financial impact on the generator which may influence the economic selection of islanding protection method.

Other dispatched generators will cover the disconnection and may also burn unnecessary fuel hence total cost to CEB may be more than this.

6.3.3 Risks to the Generator

The consequence of excessive and unwanted tripping to the generator is mostly financial due to the unnecessary loss of generation. There may also be an affect on mechanical and electrical equipment life in the case that trips are occurring daily.

6.4 Sources of Common Cause Tripping of Generators

The following devices and conditions are identified and assessed as possible causes of common cause tripping:

Loss of mains relays are the main possible cause of common cause tripping of generation. The avoidance of common mode tripping is therefore a major consideration of Section 7 on loss of mains detection methods.

6.4.1 Loss of Mains Relays

It is difficult for protection relays to distinguish between loss of mains events and general grid disturbances which may cause "nuisance" or unnecessary tripping. This is covered in detail in Section 7.

6.4.2 Voltage Relays

It is improbable that non-fault voltage excursions will exceed $\pm 10\%$ for more than 0.5 second. Such an event would also result in substantial loss of motor load, offsetting some loss of generation

6.4.3 Frequency Relays

It is unlikely that general non-islanded frequency excursions will exceed +4%, and -6%, unless there is a condition under which tripping of embedded generation would have no further impact.

6.4.4 Local Generator Instability

A fault at or close to the primary busbars or on the local transmission system, could result in pole slipping of one or more generators on the distribution network. Pole slipping can cause damage to the generator, and with larger machines, will cause extensive current surges or swings and severe customer voltage fluctuations. This in turn could cause tripping of other embedded generators.

The potential for pole slipping of large generators should therefore be assessed and protection provided if the risk is confirmed. It is recommended that generators above 5MW should be provided with pole slip protection or assessed to confirm that this is not required.

7. ISLANDING DETECTION AND PROTECTION

7.1 General

Protection relays should be used to detect abnormal electrical conditions on the grid which may indicate that an islanded condition has occurred. They may also indicate that the grid system is, for some other reason, outside operating conditions, and embedded generators should be disconnected.

After a distribution line, to which an Embedded Generator is attached, is disconnected from a grid substation, there will be some disturbance in the electrical condition on the distribution line. This disturbance may take the form of,

- a change in voltage or frequency or
- a single shift in the voltage vector or
- a change in reactive power flow.

The stand-alone detection of an islanded situation is based upon the detection of this electrical disturbance.

The magnitude and type of disturbance will depend upon the type and capacity of the generating plant, the distribution line and transformer characteristics, and the nature of the connected loads.

If at the time of disconnection,

- the remaining connected load and generated power are in balance and
- the feeder reactive power demand and generated reactive power are in balance and
- the feeder line to earth capacitance are equal for all phases,

then there will be no disturbance on the line and there will be no immediate way, apart from detection of the change of fault level, to detect an islanded situation. This balanced Embedded Generator and load situation is extremely unlikely to occur.

7.2 Islanding Detection Systems and Settings

7.2.1 General

The types of protection relays and recommended settings that are to be used to detect an islanded situation are listed in the following subsections. With the exception of the voltage and frequency types (7.2.2 and 7.2.3) the protection is known as Loss of Mains protection.

A description of the operation and use of the Loss of Mains protection is given in Annex 2.

The settings of relays should be agreed with CEB and the settings shall not be changed without the express agreement of CEB.

It must be noted that the total tripping time given under each type of protection includes any integration or timing period of the protection relay as well as relay and circuit breaker operating times.

7.2.2 Over and Under Voltage

The voltage of each phase is monitored and any excursions outside preset limits on any one phase should cause the relay to operate.

The relay should have time delay of operation based on it being long enough to avoid spurious trips due to remote faults, but short enough to ensure disconnection before out of synch reclosure.

Settings

Level for HV point of connection: $\pm 10\%$

Level for LV point of connection: $+10\%$, -14% of nominal 230 V

Note: limits should not exceed or be less than the maximum and minimum statutory voltage by more than a few percent and should be based on declared nominal voltage)

Total tripping time shall be less than 0.5 second.

In some cases, the total tripping time may be increased by agreement between CEB and the Generating Companies.

7.2.3 Over and Under Frequency

The frequency on a single phase is monitored and any excursions outside preset limits will cause the relay to operate.

Settings

Level

+ 4% , -6% (i.e. 52 Hz to 47 Hz)

This range has been selected on the basis that they are outside the normal range of frequency variation of the grid but close enough to nominal frequency to allow tripping of generator in islanded mode.

It may be possible for the low frequency to be reduced to 46 Hz given the possibility of grid recovery from 46 Hz. This will need to be confirmed with CEB. Additional generator low frequency protection may be required to ensure that there is no damage to the generator at low frequency.

Time delay

There is no requirement for a time delay.

Total tripping time shall be less than 0.5 second.

7.2.4 Rate of Change of Frequency

RoCoF relays operate by measuring the zero crossings of successive sliding cycles (or windows) of the measured voltage, establishing the apparent rate of change of frequency (RoCoF) and detecting when the applied setting is exceeded. Some RoCoF devices detect a cumulative angular shift and are also sensitive to initial change or vector shift of the measured voltage. See Annex 2 for details of "true RoCoF".

True RoCoF detects the islanded condition rather than its onset or pre-condition. It is unable to distinguish national grid and local islanding events.

Settings

"True RoCoF" operation is specified for some situations in Section 8.

Limits:

2.5 Hz/second This has been specified to ensure there is minimum spurious tripping.

Time delay

There is no requirement for a time delay.

Total tripping time shall be less than 0.5 second.

7.2.5 Voltage Vector Shift

Vector shift relays operate by measuring half cycle voltage and detecting a step change exceeding an equivalent vector shift setting. It detects a voltage vector

shift arising when there is a step change in the current through the generator internal impedance. Such a condition will be caused by a fault or the onset of islanding.

Voltage Vector Shift is inherently a protection to disconnect a generator from disturbances and is susceptible to spurious tripping during faults because it detects voltage angle disturbance rather than the characteristic of the islanded condition.

Setting

Level

6° in a half cycle. This can be de-sensitised to up to 12° where spurious tripping is experienced.

Time delay

There is no requirement for a time delay.

The maximum total tripping time shall be less than 0.5 second.

7.2.6 Reverse VARs

Reverse VAR relays operate by detecting a flow of reactive power from the generator into the grid. The technique depends on the islanded network having the typical net VAR demand and the generator having a normal operating reactive power demand (i.e. the power factor controller is set leading).

Reverse VAR protection can provide a simple and reliable method of islanding detection when there is only a single generator connected to a distribution line and where other conditions are suitable. The Captive Line Load must have a Var demand which cannot be met by other system components such as cables and capacitors.

Generators must have stable power factor control to enable reverse VAR protection to be used. The generator shall be importing reactive power under normal operation.

Tripping must be delayed to avoid loss of generation during short voltage dips (due to faults) or transient excursions of the power factor controller (especially following synchronisation or voltage disturbances).

Setting

Level

This is to be agreed between the Generating Company and CEB. Typically levels of 1-5% of the magnitude of the maximum export kW may be used. The setting will be dependent upon the generator and local load conditions

Time delay

The lesser of up to 5 seconds or 50% of the time delay of auto reclose devices.

7.2.7 Intertripping

Intertripping is a direct means of islanding protection, which provides a reliable method of tripping islanded generators without any unwanted common cause

problems. It is therefore recommended where practical for larger generators (see Section 8 for protection requirements).

It operates by sending a trip signal from the circuit breaker or recloser responsible for the islanding, to all the generators which use this method as the loss of mains protection.

The reliability of intertripping is dependent on the security of the transmission method. Pilot wires, public telephone, radio or satellite communications are possible but the reliability should be assessed on an individual basis.

Voltage barriers may be required on communication paths. Consideration must be given to the routing of intertrip signalling, to minimise the risk of interference, particularly during line fault conditions. The communication link should be reliable and fail-safe. If the communication link fails, the generator should automatically trip.

7.2.8 Fault Thrower

This is a special application of a fault thrower. It is a form of intertripping using the phase conductors as the medium for communication. The fault thrower would be installed at the source substation and would be operated following opening of an appropriate source circuit breaker. The device would either put a short circuit on the islanded feeder, creating detectable over current or undervoltage and causing operation of generator protection, or it could put an earth fault on one phase, causing the operation of generator NVD.

Operation would be delayed to allow generator relays to operate if sufficient load imbalance exists.

It would only be effective for generators connected between the source breaker and the first auto recloser.

7.2.9 Restoration

All relays should have a minimum restoration time of one minute after the CEB grid supply is restored to be within specified limits.

7.2.10 Future Developments

The Guide does not preclude the use of novel methods of achieving a dependable and reliable loss of mains function in the context of the CEB

network. An example of a possible option is the use of sensitive true RoCoF blocked by vector shift to prevent operation during general grid instability.

7.3 Islanding Network Protection

7.3.1 General

The primary protection specified in the Guide is designed to detect the islanding condition and trip the embedded generators within a safe period.

Detection of the islanded condition is not possible in all cases, especially when the load may closely match the generation on the islanded network.

Secondary protection such as dead line and synch checks on auto reclosing devices and neutral voltage displacement (NVD) relays is recommended as back-up in cases where loss of mains protection is not adequately dependable to protect against the more severe and likely consequences of islanding.

In addition, automatic low frequency disconnection relays on feeders with an average net export capability shall be rendered inoperative. The cumulative generation capability of a feeder shall be updated and compared to metered loads. This information shall be used to ensure that the current flow when restoring a tripped feeder is within the feeder and protection capability.

7.3.2 Inhibiting of Reclose Devices

Two standard methods are available to prevent closure of a circuit breaker or recloser onto a live or out of synchronised circuit,

- voltage restraint (dead line check), and/or
- synch check relay

In most applications, the dead line check will be adequate for radial lines, since the probability of prolonged islanded operation is extremely small.

Dead line check relays inhibit automatic or manual circuit breaker closure onto a live circuit. This is not islanding protection and therefore does not replace loss of mains or ensure a safe islanded condition. However, it does mitigate the risk of islanding if loss of mains does not operate.

This is a simple and dependable method of preventing out of synch closure where loss of mains protection is not secure.

Pole mounted reclosers may need to be replaced by new devices. The cost of adding a voltage relay to the source breaker control circuit is generally significantly less.

7.3.3 Neutral Voltage Displacement (NVD) Protection

An NVD scheme measures the displacement of the neutral on the HV side of the generator transformer and operates with delay when the displacement exceeds the trip setting. This device does not detect islanding, its purpose is to detect an earth fault and an unsafe islanding condition.

NVD is a dependable means of satisfying safety requirements and mitigating the risk of islanding when generators operate without parallel earthing.

NVD is implemented by having three voltage transformers (VTs) on the primary, HV, side of the connection transformer which are connected phase to ground. If HV metering voltage transformers are available, these may be of an appropriate type and may be utilised to reduce the incremental cost.

The detection relay will be used to trip either an HV or LV breaker to disconnect the generator from the line.

Voltage transformers providing NVD protection will require a voltage factor of 1.9. The time rating under voltage factor will depend on the type of system earthing at the Grid or Primary CEB substation and the fault clearance time of the NVD protection system.

The NVD protection should grade with the earth fault protection at the CEB Grid or Primary substation, so that feeder earth faults are cleared at the CEB substation before NVD protection in other feeders operate. In case of Arc Suppression Coil (ASC) earthing, the ASC should not be allowed to maintain an earth fault for a long time. It should be shorted-out in a few seconds and the earth fault protection in the faulty feeder allowed to clear the fault. The NVD should grade with the operation of this earth fault relay.

The NVD relay should be capable of withstanding three times the secondary phase voltage of the voltage transformer. Further details of NVD protection are given in Annex 3.

Setting

Level

Typically 25% of phase voltage on effectively grounded systems

This setting may need to be increased for impedance earthed systems to avoid tripping on distant earth faults.

Time delay

1 to 3 seconds depending on speed of line earth fault protection on other feeders.

8. IMPLEMENTATION OF ISLANDING PROTECTION

8.1 General

Protection relays shall be of suitable quality to provide reliable and consistent operation. The performance levels of the relays shall be declared by the manufacturer.

It is preferable to use proven protection equipment supplied by a reputable manufacturer with a track record in this type of application. The performance of all protection relays shall be within the scope of IEC protection product family Standard IEC 60255 (formerly IEC 255).

It is recommended that control and protection panels are soak tested (i.e. the protection relay panels are energised for several hours or days) prior to being put into operation. During the soak test the operation of the protection relays should be checked periodically.

Protection relays and the associated sensing circuits must be designed to maintain accuracy and operation in fault conditions. Particular consideration should be made of the requirements for current transformers to sustain operation when fault currents occur. Current and voltage transformers should be appropriately selected and comply with product standards IEC 60185 (formerly IEC185) and IEC 60186 (formerly IEC 186) respectively.

All protection relays to have indication of operation.

It is useful if the relay system can indicate which relay or function operated first to disconnect a generator during a fault condition. The indication may be reset at next breaker or contactor closure. This indication is not a requirement.

Secondary injection test points should be provided where practical to facilitate commissioning and later testing of relay settings and operation.

8.2 Interconnection Protection Requirements

In order to specify the type of interconnection protection required, Embedded Generator interconnections may be classified into one of five cases. The protection requirements for these five cases are illustrated in Figures 4 to 7.

A summary of the Case definitions and protection requirements is shown in the following table. The Cases are described subsequently.

Summary of Minimum Protection Requirements for Embedded Generator Interconnection

	Case 1	Case 2	Case 3	Case 4	Case 5	
Generator type	All	All	See Case 3 description	All	See Case 5 description	Self commutated static inverters
Minimum captive load	L	L	L		L	
Maximum cumulative installed capacity	$< 0.5 \times L$	$< 0.8 \times L$	$> 0.8 \times L$		$> 0.8 \times L$	
Maximum site installed capacity	$< 5 \text{ MW}$	$< 5 \text{ MW}$	$< 5 \text{ MW}$	$> 5 \text{ MW}$		
Under and over voltage protection	•	•	•	•	•	
Under and over frequency protection	•	•	•	•	•	
Vector shift protection	*	•	•		•	
ROCOF protection		*				
"True" ROCOF protection			*			
NVD protection			•	*(1)		
Intertipping				*		
Loss of Phase	•	•	•	•	•	•
Other	*		*	*	*	*

• Mandatory minimum requirement

* For other requirements and alternatives see the descriptions under the respective case descriptions and requirements

(1) NVD or parallel earthing

The above table summarises only the mandatory requirements of protection. Other mandatory requirements are described elsewhere in the Guide

8.2.1 Case 1

Generator Type

All types.

Conditions

- The installed generating capacity is less than half the minimum Captive Load (see note below), and
- The installed generating capacity is less than 5 MW.

Note: Minimum Captive Load is the sum of Minimum Captive Line Load and the Minimum Captive Local Load. The minimum Captive Line Load may be difficult to establish, in which case it may be assumed to be 50% of average line load.

In this case, following distribution line disconnection, the Embedded Generator speed and voltage will fall rapidly as the generator(s) will be unable to supply the load.

Protection Required

Under and over voltage

Under and over frequency

Optional, at the Discretion of the Generating Company

Three phase vector shift

Design Criteria

The minimum Captive Load is subject to change due to insertion of sectionalisers, reclosers, reconfiguration or reduction in customer load. CEB shall be informed any modification made to the Embedded Generator for review, and to assess the need for any retrospective enhancement of protection. Similarly, whenever any changes to the CEB system affects the Captive Line Load, CEB shall review the interconnection protection and advise the Generating Company accordingly.

Auto reclosers must have a minimum reclose time of 1 second to minimise the possibility of out of synch reclosure. CEB shall verify that this reclosing time is adequate for interconnection protection to operate prior to reclosing.

Figure 1 - Interconnection Protection Arrangement for case 1

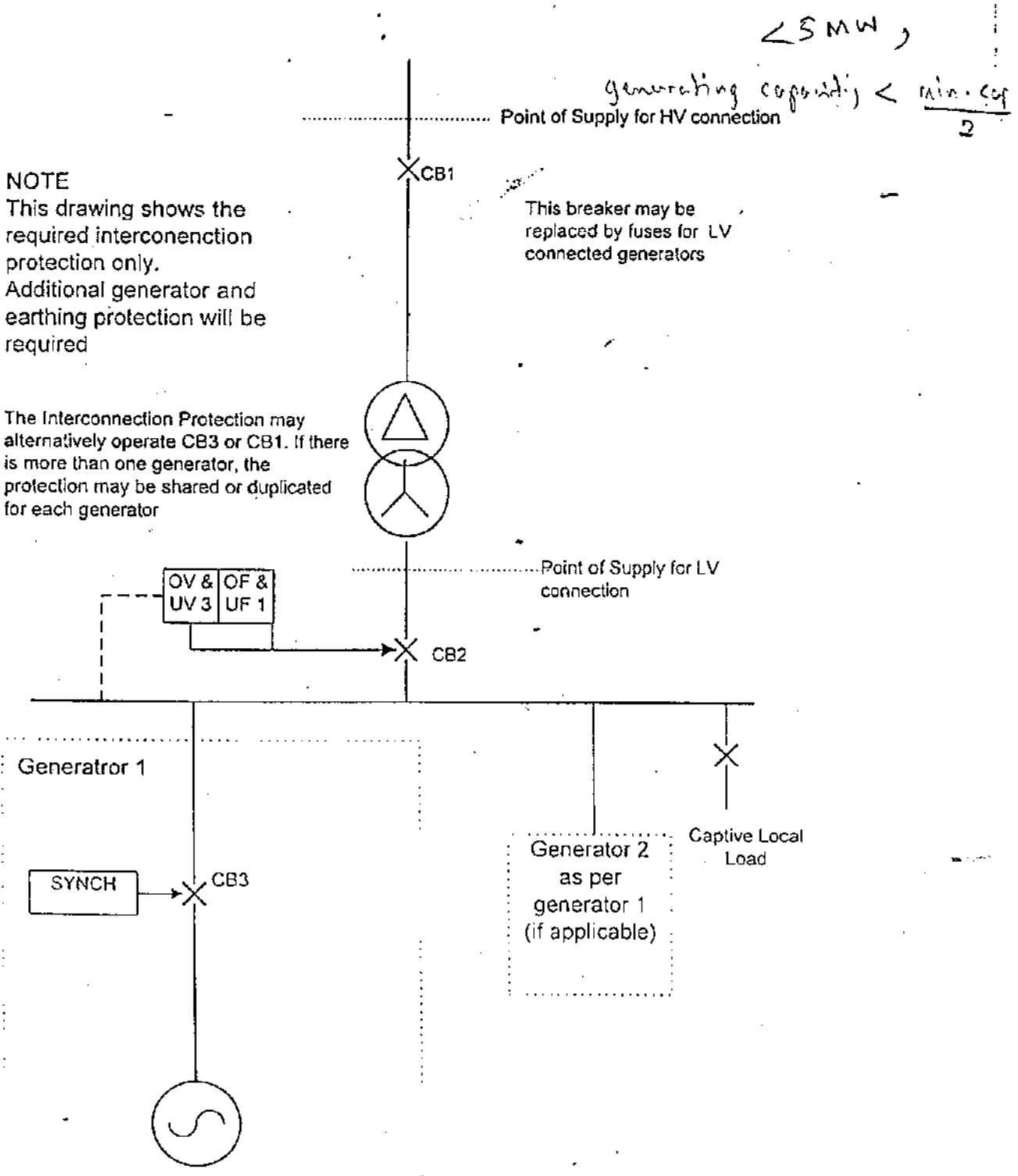

8.2.2 Case 2

Generator Type

All types

Conditions

- The installed generating capacity is **less** than 80% of the minimum Captive Load (see note below), and
- The installed generating capacity is less than 5 MW.

Note: Minimum Captive Load is the sum of Minimum Captive Line Load and the Minimum Captive Local Load. The minimum Captive Line Load may be difficult to establish, in which case it may be assumed to be 50% of average line load.

Protection Required

Under and over voltage

Under and over frequency

3-phase vector shift

Optional, at the Discretion of CEB, when a balance between Captive Load and the installed generating capacity is very likely to occur
True RoCoF may be used as well as vector shift.

Design Criteria

As per Case 1.

Figure 2 - Interconnection Protection Arrangement for Case 2

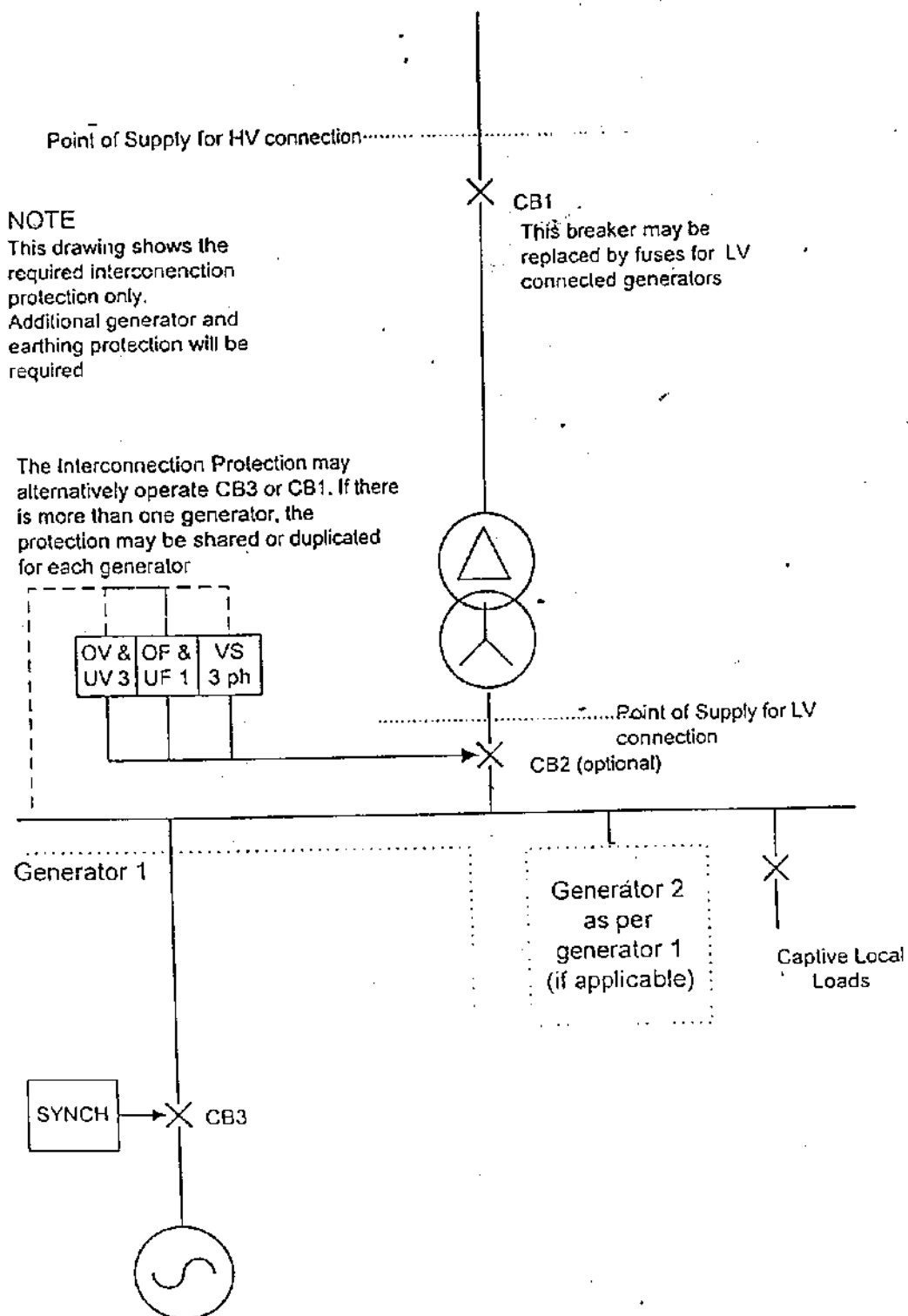

8.2.3 Case 3

Generator Type

All types except mains excited generators defined in Case 5.

Conditions:

- The installed generating capacity is more than 80% of the minimum Captive Load (see note below), such that load/generator balance is possible, and
- The installed generating capacity is less than 5 MW.

Note: Minimum Captive Load is the sum of Minimum Captive Line Load and the Minimum Captive Local Load. The minimum Captive Line Load may be difficult to establish, in which case it may be assumed to be 50% of average line load.

Protection Required

Under and over voltage

Under and over frequency

3-phase vector shift

NVD

Dead-line check

("true RoCoF" may be used in place of vector shift)

or as a replacement for the combination of Vector shift and NVD, any one of the following may be used:

Intertripping

Fault throwing

Reverse VAR protection with synchronous generators, where only one generator is connected to the circuit.

NVD protection is not required where the maximum site installed capacity is less than 1MW, if the cumulative embedded generating capacity on a distribution line that does not have NVD protection is less than 0.8 times the minimum captive load.

The fitting of deadline check relays on upstream breakers or sectionalisers, or disabling of all upstream automatic reclosing devices should be considered.

Design Criteria

The total generation connected to a single grid substation using the vector shift method for loss of mains protection shall not exceed 20MW. This is to prevent possible common cause tripping of local generation exceeding 3% of CEB grid minimum load. This limit will be increased with the increase in grid minimum load. Whenever any changes to the CEB system affects the Captive Line Load, CEB shall review the interconnection protection and advise the Generating Company accordingly.

Figure 3 - Interconnection Protection Arrangement for Case 3

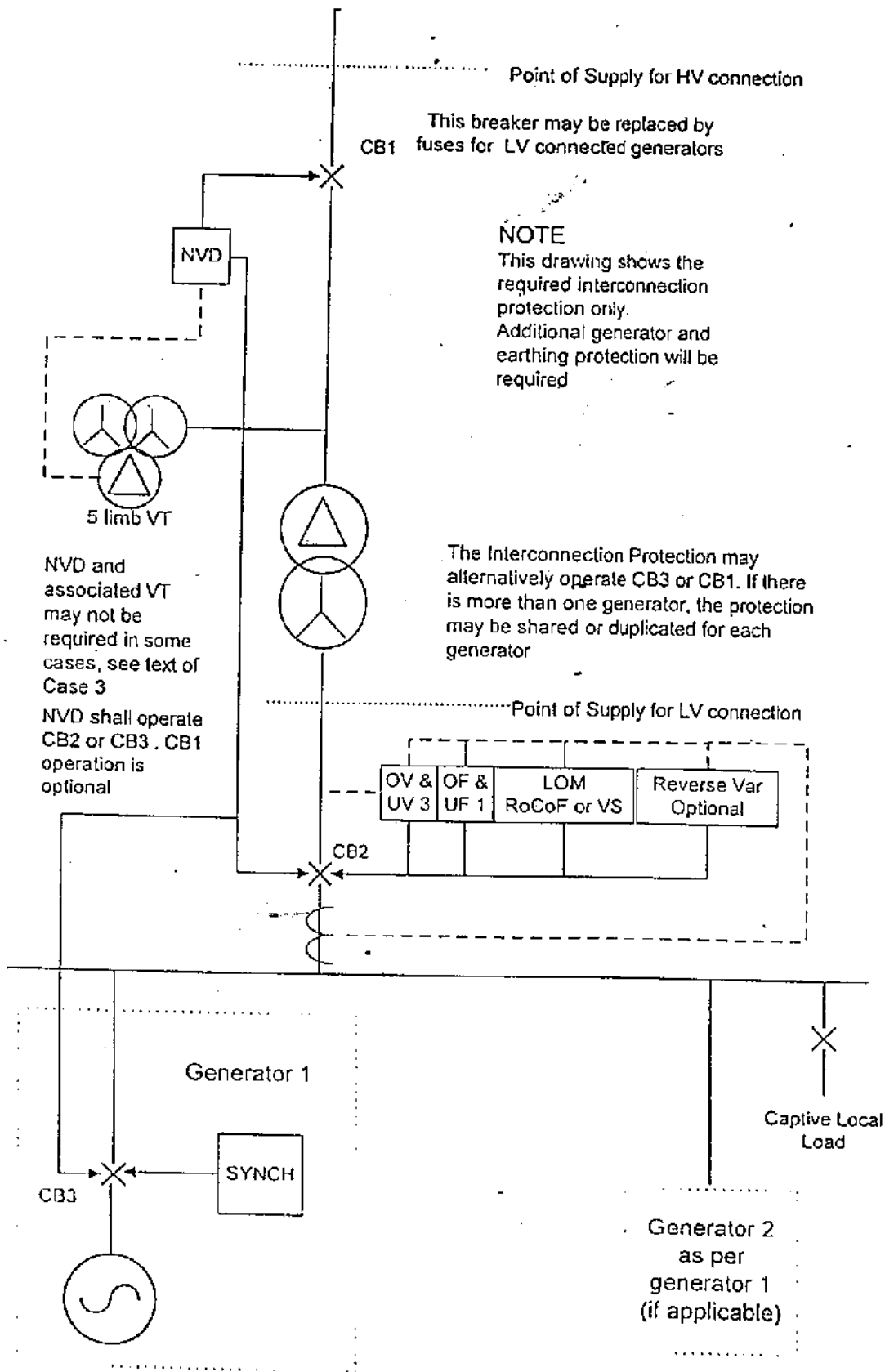

8.2.4 Case 4

Generator Type

All types

Conditions

The installed generating capacity of an Embedded Generation site is greater than 5 MW.

Configuration

It is preferred that the Embedded Generator is connected directly to the primary bus rather than feed into an HV distribution feeder.

Protection Required

Under and over voltage

Under and over frequency

Intertipping from grid substation bus intake

Parallel earthing or NVD protection

If the Embedded Generator is feed into a distribution feeder, the following is also required:

Intertipping from feeder breaker

or

Fault throwing

or

Reverse VAR protection, if applicable.

Design Criteria

Generators larger than 5 MW will be encouraged to obtain more secure connections. Insecurity is mainly a factor of the length and exposure of overhead lines to lightning and vegetation. For large generators remote from the primary bus, adequate security may only be achieved by double circuit connection to the primary bus.

Figure 4 - Interconnection Protection Arrangement for Case 4

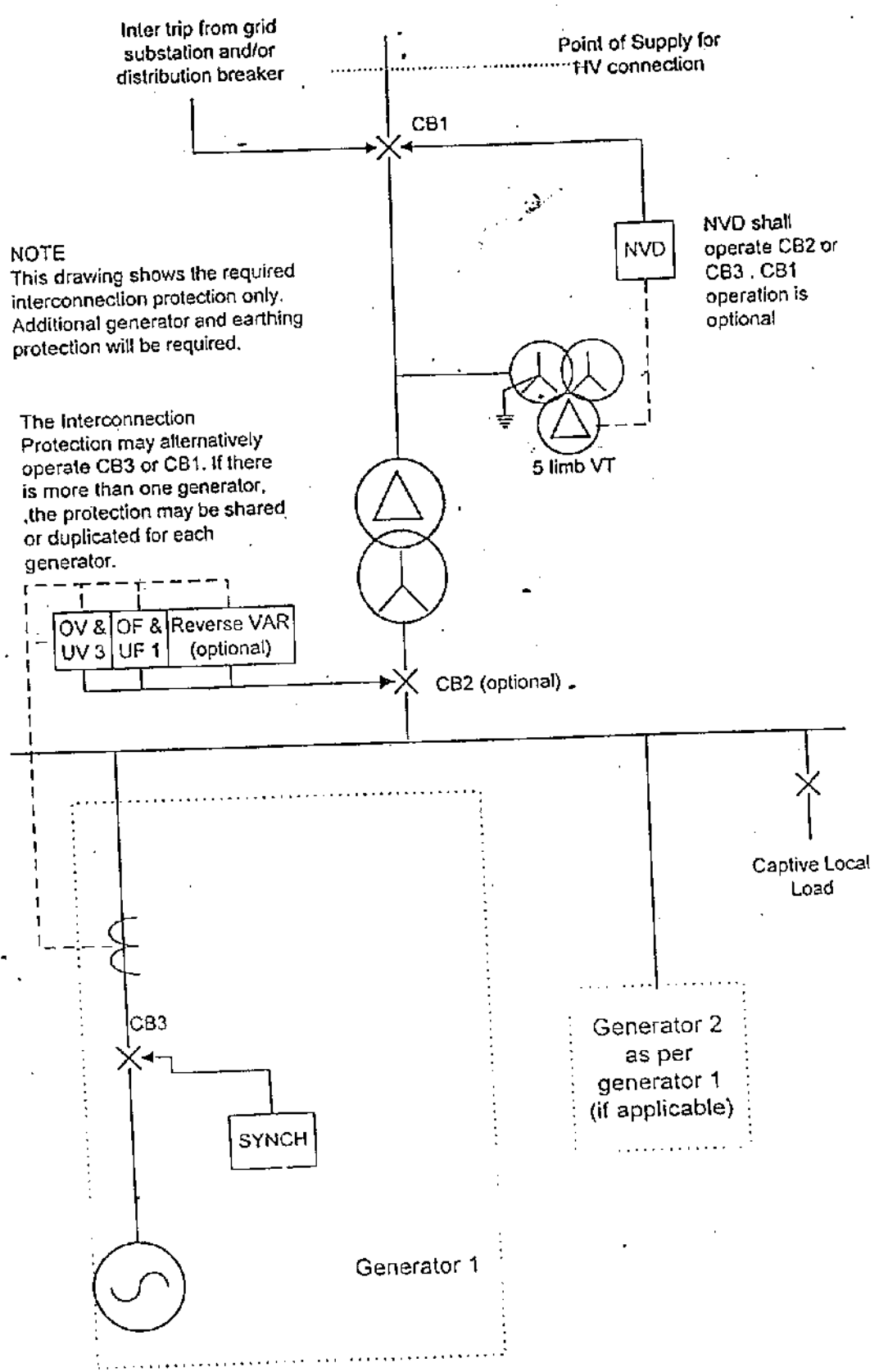

8.2.5 Case 5

Generator Type

Mains excited asynchronous generator with local power factor correction less than the reactive power demand, or a line commutated inverter.

The CEB network/circuit capacitance is not sufficient to self excite the generator.

Conditions

- The installed generating capacity is more than 80% of the minimum Captive Load (see note below), such that load/generator balance is possible, and
- No synchronous generation or self-excited generation are connected.

Note: Minimum Captive Load is the sum of Minimum Captive Line Load and the Minimum Captive Local Load. The minimum Captive Line Load may be difficult to establish, in which case it may be assumed to be 50% of average line load.

Protection Required

Under and over voltage

Under and over frequency

3-phase vector shift

Design Criteria

The total generation connected to a primary substation using the vector shift method for loss of mains protection shall not exceed 20MW. This is to prevent possible common mode tripping of local generation exceeding 3% of CEB grid minimum load. This limit should be increased with the increase in grid minimum load.

8.2.6 Self Commutated Static Inverters

The general requirements for protection of this type of generation are covered with synchronous machines in cases 1 to 5 above. However, inverters commonly include proprietary protection methods including RoCoF. The Generating Company should submit details of protection to ascertain that the generation is not susceptible to tripping for RoCoF less than 2.5 Hz/s.

If it is proposed that the protection replaces any protection specified in the cases above, it is the responsibility of the Generating Company to demonstrate that the protection meets the acceptable levels of dependability and reliability.

9. SURGE PROTECTION

9.1 General

Equipment associated with an embedded generator requires to be protected from hazardous effects of transient over-voltages.

Occurrence of transient over voltages can be due to external as well as internal causes. Lightning is the most common source for transient over-voltages. However, damaging transients could originate from within the grid system itself, due to switching operations, ferro resonance, etc.

Adequate measures should be taken to protect the insulation and equipment from being damaged due to the above conditions.

An LV/HV transformer usually connects the embedded generator to the grid system of the CEB. It is essential that the HV side of the transformer be protected from the transient over voltages by installing gapless metal oxide surge arresters with polymer housings.

The connections to earth electrodes and the design of the earth system should be appropriate for the surge protection function.

9.2 Location of the Arrester

Location of the arrester is a critical factor. In order to maximise the arrester effectiveness, all lead lengths should be made as short as possible.

Arresters require connection to the system phase conductor and earth. Inherent inductance in the leads produces a voltage build up during impulse discharges. It is usual to assume a value of 1.3- 1.5 kV/m for the lead voltage build up.

During surge conditions, the net residual voltage that will appear across the transformer will be equal to the sum of the arrester residual voltage and the voltage drops across the leads. The ability of the surge arrester to protect the transformer can be assessed by comparing the net residual voltage with the withstand voltage of the equipment.

9.3 Earthing

Current practice in Sri Lanka is to provide a separate earth for the transformer LV neutral and to link the lightning arrester earth with the transformer tank earth. When this method is adopted, under surge conditions, a potential stress could develop across the two windings. Also due to capacitive effects, transient voltages can be transferred to the LV side. Hence providing arresters on the LV side will ensure better protection for the equipment.

However, in multiple earth systems, it is advantageous to interconnect the arrester ground terminal and transformer tank earth with the secondary neutral earth. With this connection, possibility of a voltage stress developing between the two winding is minimised.

It is recommended that the embedded generator shall follow the standard practice adopted by the CEB.

9.4 Selection of the Lightning Arrester

Higher rated voltages or higher maximum continuous operating voltages and the best surge protection of the equipment are contradictory requirements. Many other system and equipment parameters have to be considered and an optimisation process has to be followed to select the basic characteristics of the arrester which will provide the best protection, to the equipment to be protected. It is recommended that the procedure given in IEC 99-5 should be followed for the selection of the arresters.

Due consideration should also be given to the following aspects when selecting the arrester.

- Service life
- Environmental aspects
- Polymer characteristics
- Energy handling capacity.

Arresters chosen shall comply with the standards adopted by the CEB.

9.5 Generators Directly Connected to LV Overhead Lines

Small generators directly connected to the distribution LV overhead lines could also be subjected to transient overvoltages. It is recommended that surge

arresters chosen according to the guidelines laid down in IEC 99-5 and capacitors should be installed between phase and earth, as close as possible to the machine terminals. Protection performance could be improved by installing a second set of arresters on the overhead line.

10. HARMONICS

Harmonic voltages and currents produced within the Generating Companies system may cause excessive harmonic distortion on the CEB system when the systems are connected.

To avoid excessive harmonic distortion on the CEB system, the Embedded Generator installation shall be designed and operated to comply with the criteria specified in UK Engineering Recommendation G5/3 or BS EN 50160.

Testing should be carried out with the generator connected to the grid and results compared to those from the grid system at the same point when the generator is not connected.

11. OPERATIONAL PROCEDURES AND REQUIREMENTS

The operational requirements and guidelines for an Embedded Generator following the commencement of commercial operation are given in the PPA.

The Generating Company must give due regard to the requirements stipulated in the Electricity Act and the Electricity Regulations. They should also ensure that all operating personnel are competent, and that they have adequate knowledge and sufficient judgement to take the correct action when dealing with an emergency.

11.1 Means of Isolation

All Embedded Generators operated in parallel with the CEB system must include means of isolation (suitably labelled), capable of disconnecting the whole of the Embedded Generating plant infeed from the CEB system. This means of isolation must be lockable in the OFF position only, by a separate padlock. Access to the points of isolation should be kept clear and unobstructed.

CEB should have the rights of access to the means of isolation without undue delay. CEB has the right to isolate the Embedded Generator's infeed at any time, should such disconnection become necessary for safety reasons and/or to comply with statutory obligations. The means of isolation should normally be installed close to the metering point, but may be positioned elsewhere with prior agreement with CEB.

A diagram showing all electrical infeeds should be displayed at the Point of Supply, or as near as practicable to it.

11.2 Earthing Facilities for Maintenance

Adequate earthing equipment, fixed or portable, shall be provided to earth an HV section during maintenance. These shall be provided at all points of isolation of the respective section or between such point and the point(s) of work. In the case of LV points of isolation of HV equipment (such as transformers), if it is not practicable to apply earths, then precautions shall be taken according to safety rules.

12. SAFETY ASPECTS

In order to safeguard persons working at the embedded generator installations and also to ensure the safety of all its plant and equipment from the hazardous situations, a Safety Code shall be implemented and used for operational activities.

A Safety Code shall basically contain:

- Responsibilities of persons and their definitions
- Levels of authorisation and competence
- Plant and equipment that are in operation and their definitions
- Voltage levels
- Safety rules which will clearly specify the actions that will be required to safeguard the person/s carrying out work on the plant and equipment from the inherent dangers
- Training of staff to safely carry out authorised tasks to a satisfactory completion
- Specialised procedures for safety when work is carried out without isolation or earthing
- Documentation required to be completed before and after a job is carried out
- Management instructions on the application of the "Safety Code".

Every employee shall be issued with a copy of the Safety Code and it is the responsibility of the embedded generator to ensure that all rules and procedures specified in the Code are strictly followed.

Instead of having its own "Safety Code", the embedded generator has the option of adopting the CEB's safety manual as its Safety Code. Under such situations, authorised persons, competent persons etc. shall be as defined in the CEB's Safety Manual, and hence it shall be necessary for the embedded generator to get its personal authorised by the CEB

The Safety Code should include the relevant requirements of national electricity regulations that apply to electrical installations

ACKNOWLEDGEMENTS

This CEB Guide for Grid Interconnection for Embedded Generators, Sri Lanka, was developed for Ceylon Electricity Board under the Sri Lanka Energy Services Delivery Project.

The Guide was prepared by,

Dr Tilak Siyambalapitiya, Resource Management Associates (Pvt) Ltd., Sri Lanka.

Mr David Roberts, Dulas Ltd., UK.

Mr Andrew Causebrook, Econnet Ltd., UK

with the assistance of,

Mr Jayasiri Karunanayake, Sri Lanka

Mr M D J Anthony, Sri Lanka

Mr Bill Rogers, UK.

The Team of Consultants thank Mr P L G Kariyawasam, Project Coordinator of Ceylon Electricity Board (CEB), and all the staff of CEB for their support during studies associated with this project. The Team also thanks the Owners and Operators of several existing Embedded Generators, Contractors and Consultants, for their support with information, discussions and plant visits.

BIBLIOGRAPHY

Electricity Act (of Sri Lanka) No 19 of 1950, No. 55 of 1955, and subsequent amendments.

Guidelines on Private Sector Participation in Small Hydro Power Development, Ceylon Electricity Board, 1997.

Standardised Agreement for Purchase of Energy, Ceylon Electricity Board.

UK Engineering Recommendation G.59/1: Recommendations for the connection of embedded generating plant to Public Electricity Suppliers' distribution systems.

UK Engineering Technical Report No 113 (Revision 1) (1995): Notes of guidance for the protection of private generating sets up to 5 MW for operation in parallel with Public Electricity Suppliers' distribution systems.

Engineering Recommendation G75 (1996): Recommendations for the connection of embedded generation plant, to Public Electricity Suppliers' systems above 20kV, or with outputs over 5 MW. -

UK Engineering Recommendation P.28 (1989): Planning limits for voltage fluctuations caused by industrial, commercial and domestic equipment in the United Kingdom public distribution systems.

BS EN 61000-3-3 (1995): Electromagnetic Compatibility (EMC) Part 3- Limitations of voltage fluctuations and flicker in low voltage supply systems for equipment with rated current less than 16A.
Equiv. IEC 1000-3-3: 1994

BS EN 61000-3-2 (1995) + A12 (January 1996): Electromagnetic Compatibility (EMC) part 3, Limits Section 2 Limits for harmonic current emissions (equipment input current <16 A per phase). Equiv IEC 1000-3-2: 1995

UK Engineering Recommendation P.29 (1990): Planning limits for voltage unbalance in the United Kingdom.

UK EA Engineering Recommendation G5/3 (1976): Limits for Harmonics in the United Kingdom Electricity Supply System.

UK Engineering Recommendation P.2/5: Security of Supply.

European CENELEC Standard BS EN 50160: Voltage characteristics of electricity supplied by Public Distribution Systems.

IEC255, (BS 5992) Electrical Relays.

BS 7430 (1991) Code of Practice for Earthing.

BS 7671 (1992) Requirements for Electrical Installations; IEE Wiring Regulations, Sixteenth Edition.

Electromagnetic Compatibility; BS EN 50081-1: 1992 (emissions) and BS EN 50082-1: 1998 (immunity).

IEC 909 (1988); Short-circuit current calculation in three-phase AC systems.

UK Engineering Recommendation G74: Procedure to meet the requirements of IEC909 for the calculation of short-circuit currents in three-phase AC power systems.

ANNEX 1- EXPLANATORY NOTES ON EARTHING

DISTRIBUTION NETWORK EARTHING

- 1.1 General
- 1.2 Earth Leakage Currents in Distribution Networks

DESIGN OF EARTH SYSTEMS

- 2.1 Transfer Potential and Limits
- 2.2 Permitted transfer voltages between HV earth systems and LV supply neutrals and networks
- 2.3 Limit of Voltage Rise Requiring Special Arrangements for Telecommunication Equipment
- 2.4 Touch Voltages in Low Voltage Supplies

Earthing Arrangements for HV and LV Distribution Networks With Embedded Generators

- 3.1 Unearthed and Arc Suppression Coil Systems
- 3.2 Effectiveness of Network Earthing
- 3.3 Earthing Factor
- 3.4 Effective Earthing
- 3.5 Non-Effective Earthing
- 3.6 Low Voltage Generators

EARTH FAULT PROTECTION

- 4.1 Neutral Point Voltage Displacement Protection
- 4.2 Earth Fault Protection for LV Generator Connections

5 EARTHING ARRANGEMENTS FOR GENERATORS

- 5.1 Earthing of HV Generators
- 5.2 Impedance Earthed Generators
- 5.3 Resistance Earthing
 - 5.3.1 Low Resistance Earthing
 - 5.3.2 High Resistance Earthing
- 5.4 Reactance Earthing

6 Generator Circulating Currents in Earth Connections

1 DISTRIBUTION NETWORK EARTHING

1.1 General

This informative annex is designed to provide background information on earthing in general. The topics covered are not all directly relevant to Sri Lanka at present, but the information is provided for reference and possible future use. Information provided in this annex shall not necessarily be taken as a requirement for a particular installation

Utility networks will be earthed at the source transformers that connect the network to a higher voltage network or to the main generators. There will normally be at least two points of earthing, because transformers are usually duplicated for security. Other earthing points may also be paralleled from time to time as a result of operational

parallel switching. Design of earth systems will take account of the most severe earth fault current. Also any significant increase of earth fault current attributed to an embedded generator will be considered in respect of the design of existing earthing systems.

Typical arrangements used to earth utility distribution networks with a range of voltages are shown in Figure 8. The diagram also shows typical connection points where embedded generators may be "earthed or not-earthed".

Earthing is effected by connecting either the neutral point of a star winding or a derived neutral point to an earth electrode system. The connection will be either solid or through an impedance. Medium voltage distribution networks, such as 33kV and 11kV, may be impedance earthed to control earth fault current, minimise cable ratings and achieve economy in the design of earth systems.

Utility 33kV networks are derived from transformers with delta windings to phase correct and limit circulating currents at mains and third harmonic frequencies. An additional 2 or 3 winding earthing transformer is then required to produce the neutral point. This may be directly earthed, earthed through a resistance or through an arc suppression coil.

Normal utility practice is to connect the earthing transformer neutral directly to ground or through through a resistance. The total impedance is designed to reduce earth fault current to 1 pu, and the dimensioning of earth systems.

The star point of a power transformer star winding is the normal method to obtain a neutral connection for networks operating with a voltage less than 33 kV. This applies to networks providing 11kV and LV supplies and allows solid, resistance or reactance earthing.

Networks with an operating voltage greater than 33kV have solid earthing at all supplying and distributing transformer windings. The larger number of network earthing points usually lead to earth fault current at utility/generator connection points greater than phase fault currents.

Multiple earthing reduces the zero sequence impedance possibly below the positive sequence impedance. Earth fault current may then exceed the 3-phase fault current. Calculation of currents must consider the impedance of the network source and circuits to zero sequence currents, any impedance in the neutral to earth connection, and the grounding resistance at the point the system is earthed and at the point of fault.

The impedance of return paths and hence the magnitude of earth fault current is heavily dependent on presence of metallic earth wires or sheaths of cables and/or resistance of earth electrodes on route.

This enhancement is unlikely at lower voltages where only the source transformers are earthed, even with solid and multiple system earthing.

Low voltage networks normally have metallic earth return paths to ensure operation of overcurrent protection devices such as fuses, where these are the sole means of protection from electric shock. This metallic path must be continuous to the point the system neutral is earthed to ensure that sufficient current is available to isolate the faulty equipment within the required time for safety.

The Sri Lankan public low voltage networks solidly connected to an earth system or electrode earth and are mostly of the TT type.

Earth fault current sensitivity for TT generator installations may be a cause of unnecessary tripping.

1.2 Earth Leakage Currents in Distribution Networks

The magnitude of current resulting from an earth fault in distribution networks is primarily determined by the network voltage, the method used to earth the neutral point of the network and the construction of circuits feeding the substation or connection point (unearthed/earthed lines or cables). Where it is found necessary to restrict the prospective earth fault current from the network or a generator by inserting an impedance between a star point and the earthing system, the value appears in the earth fault current calculation formula as 3 times its actual ohmic value. This also applies to the effects of the substation earth system resistance.

Typical range of maximum earth fault current in the HV networks in Sri Lanka is as follows:

Feeding Voltage (kV)	Method of System Earthing	Circuit Type Cable (C), Overhead (L)	Total Earth Fault Current (kA)	
			Line Construction	
			Earthed	Unearthed
11	Solid	C	3.0 - 10	0.5 - 2.0
		L	1.0 - 4.0	
11	Impedance	C	1.0 - 2.0	0.5 - 1.5
		L	0.8 - 2.0	
33	Impedance	C	1.0 - 2.0	0.5 - 2.0
		L	0.6 - 2.0	

Contributions and an increase of earth fault current attributed to an embedded generator must be considered in respect of the design and capacity of existing earthing systems. In applications where an increase of earth fault current is tolerable, solid connection of the generator neutral to an earth system is the simplest and most reliable solution. However, this will require the relevant technical factors to be considered.

Generators typically have a low zero sequence impedance compared to the positive sequence impedance. Should a generator neutral be directly connected to earth, then the single-phase prospective earth fault level at the generator terminals, may exceed its 3-phase prospective symmetrical fault level by typically 20%. This assumes typical parameters, and within the utility network, the generator earth fault contribution will be attenuated by the relatively high zero sequence impedance presented by the power lines.

Maximum enhancement of prospective earth fault levels will normally apply in the utility network close to the generator connection point.

Where a utility earth system and a generator's earth system are interconnected, generator earth fault current will flow through the interconnecting connections and will not contribute to voltage rise of the utility substation earth system

Typically an impedance of 0.85 pu inserted in the neutral of a generator restricts the

earth fault level to the full load current of the generator. The impedance can take the form of either a resistor or a reactor.

The legal requirements for safety are satisfied by compliance with relevant Standards on earthing plant and equipment in electricity networks. It is important to note that existing earthing systems, possibly designed to outdated standards, are usually compliant provided there is no record or history of danger and no significant changes have taken place. The effects of significant change to earth fault current attributed to generators must be considered as part of the connection negotiations.

2 DESIGN OF EARTHING SYSTEMS

Earth systems must be designed to handle safely the maximum earth fault current. They must also restrict site ground potential rise and ensure that touch and step voltages within and around earth systems do not exceed values permitted in Standards. If this is not practical, precautions must be taken to remove danger.

The general principle in Standards is the shorter the duration, the higher the body current which may be tolerated without risk of ventricular fibrillation. General practice is to base the design of an earthing system upon the fault clearing time of the primary or main protection, as the risk of a relay failure occurring at the same time as other adverse factors necessary for electric shock to occur are a very low order. Standards generally require improved designs to restrict the severity of rise of voltage on earth systems and also the resulting touch voltages in terms of magnitude and duration.

This is particularly important where operators may have wet footwear or make low resistance foot contact with ground.

To comply with Standards, it is firstly required that all practical steps must be taken to keep the potential rise of the earth grid below the level which otherwise would require special precautions within a site.

2.1 Transfer Potential and Limits

Voltage rise on a utility or generator 33 or 11 kV earth system will be transferred to LV neutral conductors and LV earth terminals where these are connected to this earth system. Limits for permitted voltage rise on shared or interconnected 33 or 11 kV earth systems and LV neutral earth systems now appears in Standards.

In addition, where a voltage rise may be propagated throughout premises via LV supplies and protective conductors, CCITT codes of practices (now draft ITU and Cenelec Standards) stipulate safety and damage limits for telecommunication equipment that may be externally referenced to remote earth potential.

Figure 9 shows the earth systems that may be present for a LV generator connection to a 33 kV overhead line.

2.2 Permitted transfer voltages between HV earth systems and LV supply neutrals and networks

BS7430 permits voltage rise up to 430 V on shared HV and LV TN earth systems.

HD 637 S1 1999 proposes a transferred voltage rise for single point earthed TN systems up to the basic touch voltage limit. This is the touch voltage without additional protection (500 V for 200ms, 220 V for 500 ms or 100 V for 1 second). Generator LV systems are normally of this type.

HD 637 S1 1999 also proposes a limit for transferred voltage rise typically up to two times the basic touch voltage limit for TN-C systems with multiple earthed neutrals.

LV systems and Generator systems (TNS systems) with multiple connections of cable sheaths/protective conductors to an independent above-ground earth system have similar characteristics and may be assumed to qualify for this limit.

2.3 Limit of Voltage Rise Requiring Special Arrangements for Telecommunication Equipment

Special isolation facilities and insulation are required for metallic conductors and cable screens that may be referenced to remote earth when the rise of potential on the local earth grid may exceed the voltage limit. Voltage limits are under review and for the present, the limit should be taken as a voltage rise of 650 V (exposure time not exceeding 200 ms) or 430 V.

These voltage limits differentiate between basic and enhanced insulation of telecommunication equipment.

It is also important to maintain safe operating conditions, and it is left to the protective earthing and bonding measures taken within installations to ensure that appropriate touch voltage/time limits are not exceeded.

A zone (hot zone) requiring special treatment may extend around an installation's earth system electrodes. This is a ground surface contour defining the appropriate voltage limit.

Precautions to be taken within the "hot zone" may take the form of insulated inserts in metal pipe-work, external insulation, electrical barrier equipment and safe isolation facilities for cable cores.

Power or telecommunication cables may also transfer an earth grid potential rise to remote termination points. This may produce the highest possible touch voltage and is the value normally used for calculations.

Should the maximum voltage rise be less than the 650 V (or 430 V) limit, no special precautions are required.

2.4 Touch Voltages in Low Voltage Supplies

Touch voltages associated with LV plant and LV supplies are determined by the design of the LV installation and compliance with the Wiring Standard (BS7671). Compliance

with the requirements for earth faults on LV equipment and at distribution points will minimise risk of dangerous electrical shock.

3 EARTHING ARRANGEMENTS FOR HV AND LV DISTRIBUTION NETWORKS WITH EMBEDDED GENERATORS

3.1 Unearthed and Arc Suppression Coil Systems

Unearthed network arrangements may be encountered in small or private networks. Such networks will not have connections capable of passing sufficient fault current to operate standard non-directional protection devices. They must comply with the Regulations and appropriate protection measures will be in place for safety.

Very high impedance connections to earth may exist such as at the primary winding of a voltage transformer or the coils or inputs of relays and instrumentation. These are fortuitous earths and may be of higher impedance than network capacitance.

Under normal balanced conditions, capacitance in a three-phase cable system is substantially phase balanced and there are similar phase voltages to earth. Where a neutral point exists, this will be near earth potential and arrangements for neutral displacement protection may not be immediately effected.

The first earth fault to occur in an unearthed system will cause little damage or disturbances, since only capacitive currents will flow. Typically in small systems such as a generator this may be a few amperes.

Voltages on sound phases will be elevated to line voltage above earth potential and if insulation is not designed for this, and if undetected, may cause immediate insulation breakdown or aging and breakdown. It is important to identify and remove the first fault as quickly as possible.

The possibility of a second coincident earth fault at another point in the network must be considered. This second fault may create "cross country" fault conditions with considerably more current involved. The locations of such faults are unpredictable and the maximum current an earth system may be required to handle should be appropriate

for a simultaneous "second" fault.

The order of capacitive currents for a single fault may be lethal and it is normally time consuming to locate faults in larger systems.

Resonance may occur on these systems and may lead to overvoltages. The most common source is network capacitance resonating with an earthed high value inductance such as a power transformer or a protection or instrument transformer having an earthed winding. Depending on local conditions, high circulating currents or overvoltages may occur at the resonance frequency.

An intermittent fault may create "arcing ground" conditions and also produce similar high voltages. This may occur where arcing through high impedance produces trapped charges on phase and neutral conductors. The charge may progressively build up during each successive arcing burst. Excessive voltages may be built-up (theoretically up to 5 or more times rated voltage) which may damage plant insulation.

High impedance tuned reactance earthing is becoming more common in 33 and 11 kV systems to reduce fault disconnections and minimise lost supplies. This is arc suppression coil earthing (ASC) which is designed to resonate with system zero sequence earth fault capacitance and reduce arc current in air for an earth fault to zero.

It should be noted that leaving an ASC connected to a permanent earth fault is a source of common mode tripping of all Generator NVD protection in a network.

Appropriate measures such as short circuiting the coil after a short time delay (typically 3 – 4 seconds) may be required for discrimination with NVD protection (set typically 6 – 10 seconds) to prevent this.

3.2 Effectiveness of Network Earthing

Insulation of electrical plant must accommodate voltage rise on sound phases when an earth fault occurs. The low source voltage in LV networks normally ensures that maximum phase voltages with respect to earth remain substantially close to normal phase to neutral values, while metallic paths are available for network fault current.

This is not always true in 33 kV and 11 kV networks.

The effectiveness of system earthing is often a specified quantity in terms of the control of voltage rise on sound phases.

It is quantified by the control of the voltage rise on sound phases when an earth fault occurs.

Solid earthing by solidly connecting a neutral point to a low value earth electrode or a "global" earth system will normally be "effective".

In medium voltage networks, any impedance placed in the neutral connection, to control earth leakage current will be at the expense of earthing effectiveness and will produce voltage rise on sound phases.

3.3 Earthing Factor

The earthing factor at a given point in a network is the ratio, normally expressed as a percentage, of the highest RMS voltage on a sound phase during a fault to earth to the line-to-line RMS voltage at that location, with no fault.

3.4 Effective Earthing

Solid neutral earthing is obviously required for effective earthing. This is the direct connection of the neutral point to a low resistance earth electrode system. A network with an effectively earthed neutral at a given location may be characterised by an earthing factor less than 80%. This corresponds to a voltage rise less than 140% of normal phase to neutral values.

In determining effectiveness of earthing at all parts of a network account should be taken of the appropriate impedance of earth systems and cables and lines.

It should be noted that where parallel metallic paths exist for earth fault current, the zero sequence impedance of cables and lines are changed. Typically zero sequence reactance increases and zero sequence resistance decreases with the end result being lower zero sequence impedance. In these cases the Standard definitions for effective

earthing in terms of sequential impedance requires careful application.

3.5 Non-Effective Earthing

Where it is necessary to control earth leakage current a medium voltage network may incorporate impedance in the neutral/earth connection. This is at the expense of voltage rise on sound phases, which may rise to near the normal line to line value. A network with a non-effective earthed neutral at a given location may be characterised by an earthing factor greater than 80%.

This applies also to or ASC which resonate with network capacitance to reduce earth fault arc current in air.

3.6 Low Voltage Generators

Generators may be directly connected to LV feeders or substation busbars that also supply general load.

When operating in parallel with utility supplies away from distribution substations, generators may have their neutral points disconnected or disconnected from earth to minimise risk of damage from network unbalance current and also broken neutral connections.

When operating in parallel with utility supplies at a distribution substation LV busbar, a generator may be permitted to operate in parallel, with an earthed neutral point. This will normally apply where the network is of the TN-C (PME) type with the utility distribution substation adjacent to the generator premises.

A low voltage generator may be connected via its own transformer or a utility or transformer directly to a high voltage circuit. This will be a MV connection and subject to consideration of the general technical factors. The generator LV system earth may remain in place when operating in parallel with the utility MV network.

4 EARTH FAULT PROTECTION

- A persistent current generator current to a network earth fault may be detected by measuring the earth fault current, the resulting voltage displacement of the neutral point with respect to earth. This will normally be after islanding using NVD protection for mitigation.

Earth fault protection may be provided in the conventional manner using either the residual current from a 3-phase set of current transformers, or a current in the neutral earth connection of a generator or generator step-up transformer.

4.1 Neutral Point Voltage Displacement Protection

Neutral Voltage Displacement (NVD) protection may be applied at a generator site or in the case of several independent generators at a nearby point in the network where it may be possible for the group of generators to back-energise a MV network that may be unearthed, if islanded to the generators.

An earth fault in an unearthed network is an extreme example of in-ineffective earthing and neutral point voltage displacement.

Neutral Voltage Displacement protection is explained in Annex 8.

4.2 Earth Fault Protection for LV Generator Connections

A LV generator connected to utility LV networks away from the main LV distribution substation will not normally operate with a parallel neutral to earth connection. Because of the predominant use of TT supply earthing the generator should have an earth system. Preferably this should be interconnected with a utility earth terminal where this is available or be a shared earth system. This will provide a metallic earth loop path to operate generator protection for an earth fault and reduce the sensitivity for local faults which otherwise would be required for generator earth fault devices.

The Wiring Standard applicable to buildings and their installations require protective devices to operate in a defined time to reduce risk of shock or fire. The installation design will normally be based on the source impedance of supplies from the distribution

network.

While it will not be generally acceptable for a LV generator to operate islanded and independently supply load in the utility LV network, it may operate islanded to its own loads. Under these conditions, it is important that the fault current provided by the generator is adequate to maintain safe performance of the installation's protection devices. This includes any overcurrent devices and those used to detect earth leakage current.

To ensure the correct operation of LV earth leakage protection, the source earth loop impedance should not exceed declared or measured values used for the design of the electrical installation. Where these are exceeded, the additional generator backup protection should be provided with an appropriate sensitivity.

5 EARTHING ARRANGEMENTS FOR GENERATORS

Typical methods that may be used to earth a generators system. The generator or its associated power transformer with a star winding is the most convenient method to obtain the neutral connection. However, delta windings may also be used to phase correct or limit circulating currents at triple harmonic frequencies. In these cases a separate dedicated 2 or 3 winding earthing transformer may be used to produce the neutral point.

Basic Options for Generator Earthing

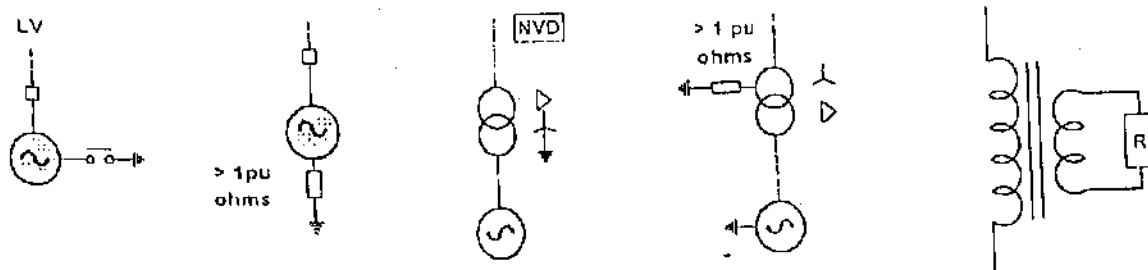

The above Figure shows options that are generally used to earth generators while operating independently or if agreed, in parallel with electricity supply systems. These

are summarised in broad terms below:

- Direct (solid) earthing
- Resistance earthing
- Reactance earthing
- Transformer earthing

For impedance earthing the impedance may be placed between the generator star point or a transformer star point and the earth system.

Within a generator site, it is also necessary to comply with standards such as BS7430 and possibly BS7671 to satisfy Safety Regulations. This will normally require a generator neutral to be earthed when operating independently of the utility supplies.

1 Earthing of HV Generators

There are relatively few technical obstacles to prevent MV generators with appropriate impedance earthing operating in parallel with the utility MV networks. Where this is the case, the protection interface is simpler. Impedance earthing limits fault current, circulating current and harmonic current. It also minimises detrimental effects on utility earth systems and network protection.

The major issue arises where a utility MV network may be designed as an effectively (solid) earthed system. In this case, it is important that an impedance earthed MV generator does not operate islanded without the utility system earth. The generator alone will not provide an effective earthed system.

A 11kV generator may be directly connected to a 11kV circuit without a transformer. Subject to the criteria for parallel earthing being satisfied, the generator may also be impedance earthed and operate with a parallel system earth connection. However, for this the utility must consider the size of the generator and the previously stated technical considerations for parallel earthing.

Multiple earthing of a Generator and the utility network may be avoided and prevented by use of suitable transformer windings or the interlocking of switches. This will

ensure, where required, automatic earthing of the generator neutral only when the incoming mains is disconnected.

Where a generator is required to operate independently of utility supplies, it must have it's an earth electrode system, which may be interconnected to a utility earth system or terminal on the premises or a shared earth system.

5.2 Impedance Earthed Generators

Impedance earthing of a generator is common in MV systems. Devices such as resistors or reactors are acceptable to satisfy the technical criteria for parallel earthing in non-effective earth systems.

Low value resistance earthing is commonly used to limit earth fault current while still operating protection relays. An acceptable alternative is reactance earthing.

An impedance earthed generator requires protection, such as standby earth fault protection, to protect the earthing device and detect continuous low value earth leakage current. Alternately, a single phase VT may be placed across the resistor to establish NVD protection for the same function.

Where connections are to 33kV unearthed overhead lines, away from the source substation, higher sensitivity may be present in the line protection schemes (sensitive earth fault protection and alarms). In these cases generator earth fault current must be very low to prevent false operation of line protection.

The preferred arrangement is a voltage transformer for both earth referencing and neutral voltage displacement protection to detect earth faults without passing significant current.

5.3 Resistance Earthing

Resistance earthed systems may be classified according to whether they present a high or a low resistance.

5.3.1 Low Resistance Earthing

A resistor can either be introduced directly in the neutral circuit or via a transformer with the resistor inserted in the secondary winding. Where the resistor is of a relatively low value (ie resulting in earth fault levels equal to typically 0.5 pu to 1pu of generator full load current), then direct insertion of the resistor is a simple and reliable technique.

Low resistance earthing provides greater prospective earth fault levels and hence greater flexibility in the grading of system protection. The lower limit on the value of the earthing resistance is typically that which provides earth fault current no greater than rating. Likelihood of damage due to overcurrent in generation and distribution equipment is hence kept to a minimum.

5.3.2 High Resistance Earthing

High resistance earthing limits the prospective earth fault current and hence limits damage in the system or in the generator by earth fault current. In addition, this minimises the shock hazard presented as possible touch or step potentials. In the extreme, high resistance grounding may resemble an unearthed system and allow prolonged operation with a system earth fault until it can be conveniently isolated and removed. Typically, high resistance earthing is used for generator windings and step up transformers.

The minimum acceptable earth fault current is usually a balance of these advantages with the need to achieve adequate discrimination margins on protection relays, minimise voltage stress on insulation systems and limit the tendency for unwanted transient overvoltages.

In order to limit overvoltages, the earthing resistance should be no greater than 1/3rd the capacitance phase reactance of the connected system.

Resistors with high ohmic values are less robust than low value ones.

Transformer coupling may be used with a suitable turns ratio to allow the use of a more robust resistor.

$$R_{(HV)} = R_{(LV)} \times \text{Turns ratio}^2$$

Typically the turns ratio will be about 44 and hence,

$$R_{(HV)} = R_{(LV)} \times 1936$$

A small MV/LV distribution transformer may be used in this impedance matching mode.

5.4 Reactance Earthing

In principle, reactor earthing offers advantages over resistor earthing. The reactor is a low loss device and in addition, presents impedance directly proportional to frequency. It may therefore be used to increase the impedance to harmonic frequencies (multiples of power frequency). This has advantages where generator circulating harmonic currents may be a problem.

Very high reactance earthing is not generally favoured for generator systems or for industrial applications.

This is because of general concern over the increased likelihood of transient overvoltages and arcing damage at points of fault.

A star-star generator transformer may be used having one of the windings unearthed. This arrangement increases the transformer zero sequence reactance and severely restricts earth fault currents.

6 GENERATOR CIRCULATING CURRENTS IN EARTH CONNECTIONS

Where two or more generators operate in parallel with their star points/neutrals connected to a common neutral conductor or an earthing busbar, harmonic currents may circulate between machines. For harmonic currents to circulate, differences in harmonic voltages must exist between the machines and this may influence their possible operation with parallel neutral and earth connections.

The voltage waveform produced by the synchronous generator is primarily determined by the flux density distribution round the air-gap. In a salient pole synchronous

machine, pole faces may be chamfered to reduce harmonic content of the voltage waveform. Also, in a cylindrical rotor machine, the way the rotor winding is distributed can achieve similar improvements. A perfectly sinusoidal voltage is rarely obtained and some harmonic voltages will invariably be present in the generator output voltage. Typically low order harmonics such as 3rd and 5th are dominant.

Typical effects of harmonic current flowing in earth connections are telephone interference, heating of a neutral earthing resistor and derating of a generator.

Harmonic currents must also be considered in determining the sensitivity for earth fault protection or alarm devices. Earth fault protection is usually provided by a CT and relay in the generator neutral/earth connection. This will respond to system earth faults in addition to those on the generator winding. If this is too sensitive it may be subject to operation due to out of balance and harmonic currents in the generator neutral. Sensitive and fast earth fault protection of the stator core is best provided by differential protection. This will give the most extensive coverage of the winding with typically only 5% of the neutral end winding being unprotected.

Parallel earthing of a generator and the utility network neutral earth system will form an external zero sequence loop. Triple harmonic voltages (3rd and multiples) because of their relative and additive phase displacements may produce significant circulating currents between the generator neutral and the external earth connections.

Other harmonics such as the fifth and seventh harmonics form a balanced set of voltages and little circulating current.

Such a loop may also include other earthed plant sharing the network with the generator. This may be another generator, a transformer or the capacitance of system cables.

The amplitude of harmonic currents in the circulation path and harmonic voltages will be increased if resonance occurs.

Parallel generator earthing will be accepted subject to circulating harmonic currents not exceeding limits that are defined by standard G5/3 or BS EN 5016.

Where two or more generators provide alternative supplies to a site, their neutrals may be solidly earthed. Generally, triple harmonic voltage components produced by modern salient pole generators are such that in general additional measures will not be required to limit circulating currents.

Circulating current problems could however arise if machines of different age or manufacture are operated in parallel and switching of their neutral points may be required so that only one is earthed at a time. For this, the prospective neutral current must be within the rating of a single earthed generator.

Where single-phase loads predominate this may be a problem and to share neutral current, parallel neutral connections and earthing only one generator may not be possible.

In these cases, a phase balancer or earthing transformer is the preferred method to earth all the generators and produce a generator neutral connection to overcome circulating current problems.

Figure 5 - TYPICAL EARTHING OPTIONS FOR NETWORKS WITH EMBEDDED GENERATORS.

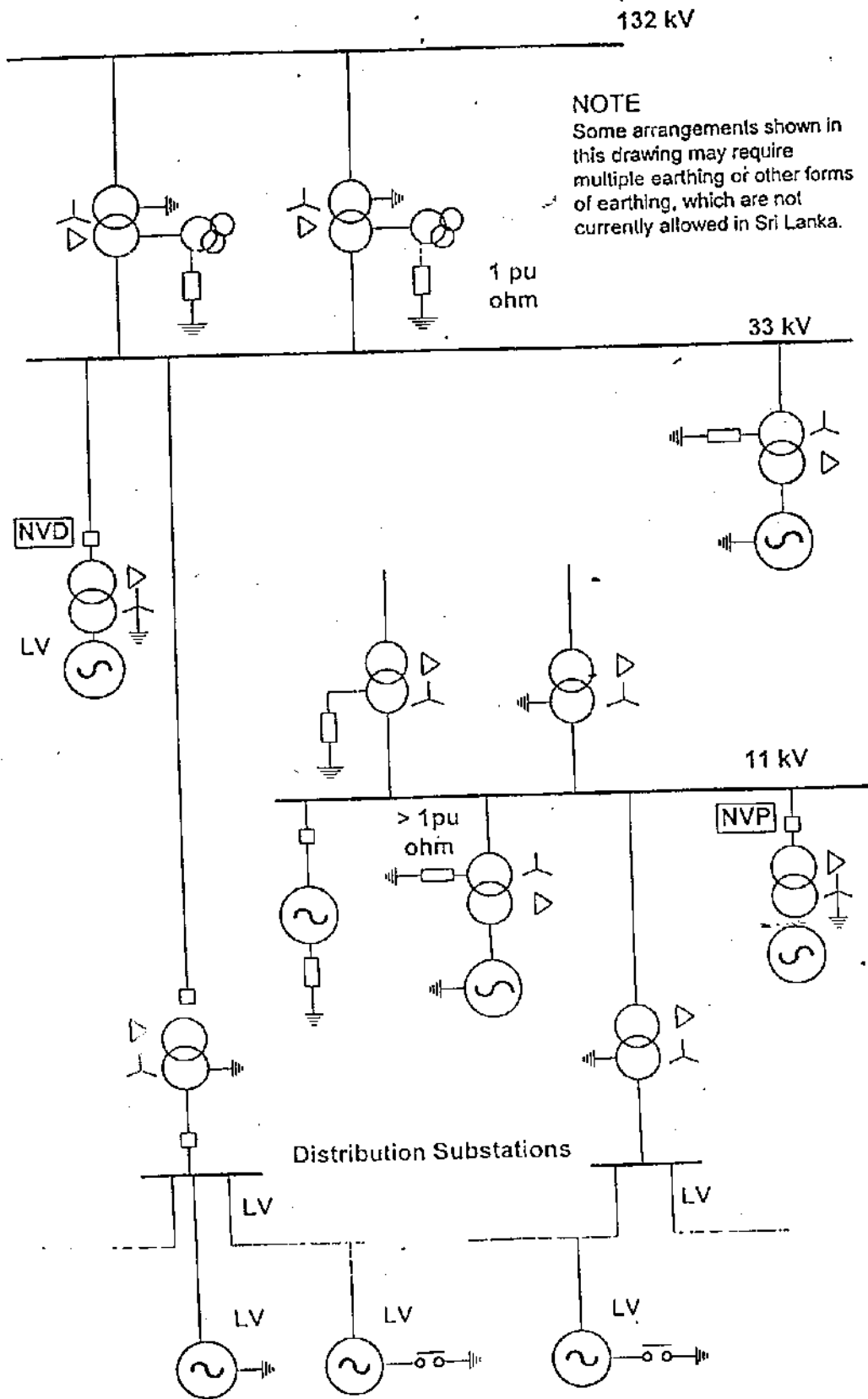
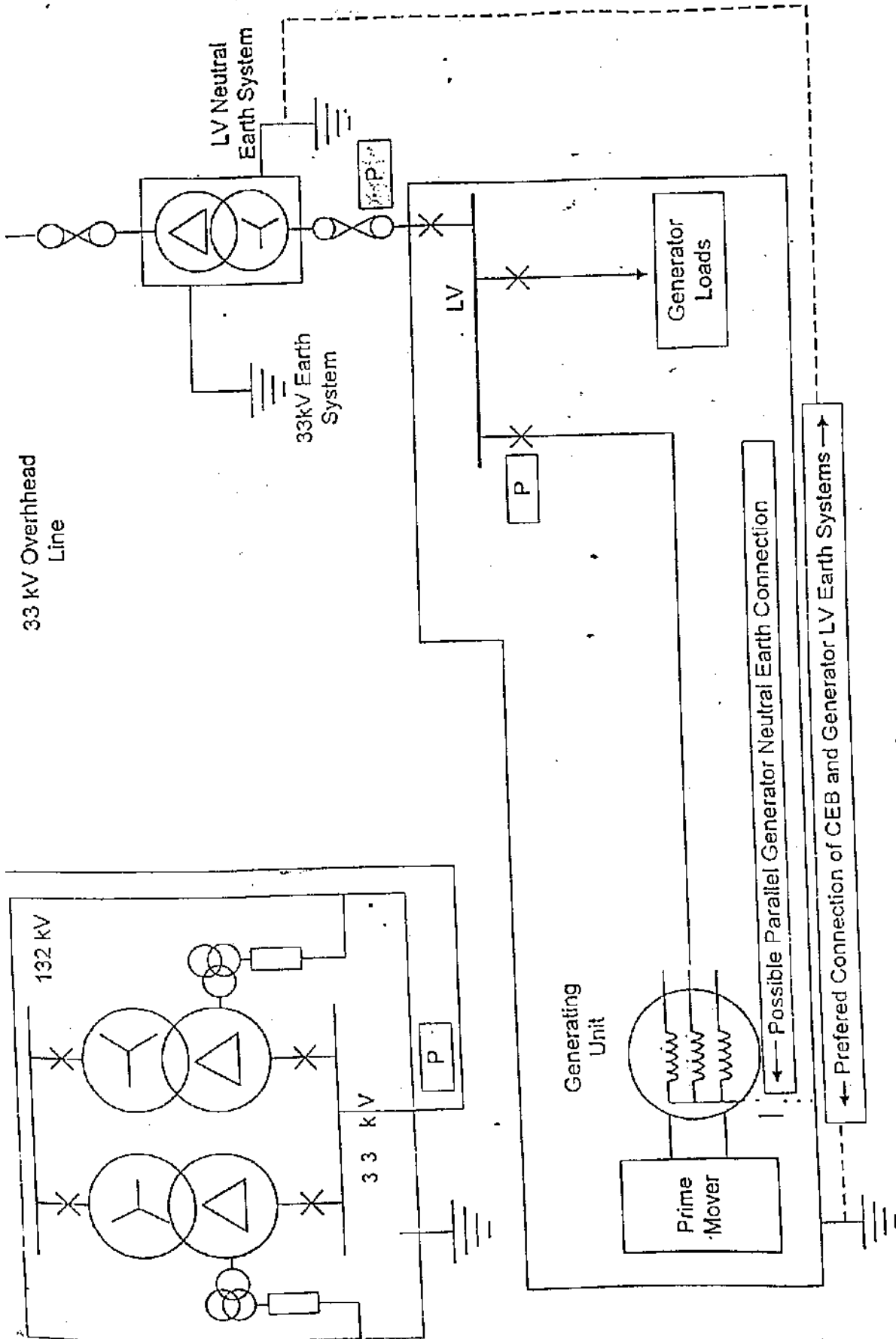

Figure 6 - CONNECTION OF EARTHING SYSTEMS ASSOCIATED WITH LV/33kV GENERATORS



ANNEX 2 – EXPLANATORY NOTES ON ISLANDING DETECTION AND PROTECTION

1. RATE OF CHANGE OF FREQUENCY

Some RoCoF relays operate by measuring the zero crossings of successive sliding cycles of the measured voltage, establishing the apparent rate of change of frequency (RoCoF) and detecting when the applied setting is exceeded.

Some basic RoCoF devices are also sensitive to initial change or vector shift of the measured voltage. Those that are immune to this may be referred to as "true RoCoF" devices. True RoCoF is not sensitive to transient disturbance but to the progressive frequency change due to an imbalance of a generator or combined generation and load on the system.

RoCoF detects the islanded condition rather than its onset or pre-condition.

Typically, a 10% load imbalance will lead to a RoCoF of 2 Hz/s although this is dependent on the type and inertia of the machines connected to the islanded network (note that a 10% imbalance on the national grid can cause a 1.97 Hz/s RoCoF according to CEB studies).

Key features:

The Sri Lanka national grid is itself an islanded system and therefore the RoCoF effect at the national level is inherently indistinguishable from local islanding.

On the basis of studies by CEB, settings less than 2.5 Hz/s could contribute to national grid instability by disconnecting generation at critical times.

RoCoF setting of 2.5 Hz/s is less sensitive to local islanding: a load imbalance of 4 - 15% would be required to operate the relay depending on the inertia constant of the islanded network.

Advantages:

Cheap and may be quite fast acting for large imbalance.

Disadvantages:

Unable to distinguish national grid and local islanding events. An acceptable setting to avoid a detrimental effect on the Sri Lanka grid leads to less sensitive islanding protection.

2. VOLTAGE VECTOR SHIFT

Vector shift relays were initially used to disconnect generators during local disturbances and have successfully been used to detect islanding disturbances.

They operate by measuring half cycle voltage periods (time between zero crossings) and detecting a step change exceeding an equivalent vector shift setting (typically between 6° and 12° in a half cycle). It detects a voltage vector shift arising when there is a step change in the current through the generator internal impedance. Such a condition will be caused by a fault or the onset of islanding. If there is no preceding fault then the sensitivity to islanding is low (6° is equivalent to about 1.67 Hz/s or about 10-20% load imbalance).

The magnitude of vector shift progressively diminishes from the point of circuit fault towards the primary bus bars and through the infeeding transformer/s. Transformer impedance is significant and the vector shift imposed at the bus bar is transferred to all the un-faulted feeders on the local network. For this reason, there will inevitably be line faults that can cause all vector shift relays on the local distribution network to operate simultaneously. It is for this reason that the total capacity of generation with vector shift protection must be limited as defined in the guide.

Key features:

Voltage Vector Shift is inherently susceptible to spurious tripping during faults because it detects voltage angle disturbance rather than the characteristic of the islanded condition.

All relays connected to a medium voltage network, sourced from a primary bus will probably be activated by a single fault close to the bus.

If the islanded condition is not preceded by a fault (i.e. by underfrequency or manual tripping of feeder breaker), then the relay is unlikely to operate where load and generation are closely matched and voltages are substantially normal.

The ability to discriminate between islanding and other faults is improved when faults occur at electrically distant points.

Three-phase detection, requiring vector shift on any phase, increases dependability of islanding protection, but may also increase the number of spurious trips.

Three-phase detection, requiring simultaneous vector shift of the same direction on all phases, would reduce the number of spurious trips but may also reduce the dependability of islanding protection since most onset fault conditions are excluded.

Advantages:

Cheap and fast acting.

Disadvantages:

Inherently liable to common mode tripping for local distribution faults and possibly nearby 132 kV faults. Insensitive to the onset of islanding.

3. REVERSE VARs

Reverse VAR relays operate by detecting a flow of reactive power from the generator into the grid. The technique depends on the islanded network having the typical net VAR demand and the generator having a normal operating VAR demand (i.e. the power factor controller is set leading).

Key features:

Generators must have stable power factor control.

Margin between relay setting and normal VAR import must be greater than control limits of the power factor controller.

Exceptional networks may not have a net VAR demand (long capacitive cable feeders with resistive load and/or low minimum demand).

Operating at leading power factor is less stable and introduces additional thermal losses.

Tripping must be delayed to avoid loss of generation during short voltage dips (due to faults) or transient excursions of the power factor controller (especially following synchronisation or voltage disturbance).

Three-phase detection is advised for overhead lines where partial islanding could be initiated by a break in a phase conductor.

Complications arise where more than one generator is connected to a line or small network because one of the generators may supply the VAR demand of the network or VAR oscillations may occur.

Advantages:

Simplicity and immunity to general common mode tripping.

Disadvantages:

Requires generation at leading power factor with consequential losses.

Slower acting than vector shift or RoCoF.

Dependability of islanding protection for all types of network and for multiple generators is not assured.

4. INTERTRIPPING

Operation

Intertripping is a direct means of islanding protection. It operates by sending a trip signal from the circuit breaker or recloser responsible for the islanding to all the generators which use this method as the loss of mains protection. It should be noted that there may be more than one trip source because there may be more than one level of islanding possible.

Intertripping must be initiated from all points on a circuit, downstream of which the minimum load may not overload a generator or operate its loss of mains protection.

Intertripping may be used to disconnect a single generator and ensure multiple smaller generators are mismatched by trapped load.

The reliability of intertripping is dependent on the security of the transmission method. Private pilot wires, public telephone or satellite communications are possible but the reliability should be assessed on an individual basis.

This will typically be an expensive method of protection and will usually only be considered for larger generators close to the primary substation.

Application

An inter trip may be implemented using a secure communication channel between the sub station and the generator. A secure communication channel will consist of a fixed wire or fibre optic link. Radio or cellular phone communications are not presently considered to be reliable for inter trip purposes. It should be implemented in a fail safe manner, such that if there is a failure in the communication channel, the generator will disconnect from the grid.

An intertripping system is typically unqualified and trips the generator upon opening of the source circuit breaker without further checks. It is made more complex where there is more than one breaker that can initiate islanding. For example, a generator remote from the primary may be islanded by a field auto recloser, the feeder breaker and/or the primary substation breakers. The risk of islanding at each level would need to be assessed before establishing the scope of the intertripping scheme.

Key features:

The principle cost is for a reliable means of communication for the trip signal from the initiating breaker(s) to the generation site.

Options are: buried or overhead (underslung or wrapped) pilot cable or wires (fibre optic or metallic conductor), power line carrier signals, rented channels via

Part 2: Protection and Operation of Grid Interconnection

public telecom or, radio signals. Each method should be assessed for dependability of operation and susceptibility to spurious trips. A less dependable method may be acceptable when used in conjunction with another loss of mains device.

Advantages:

Generally dependable.
Generally immune to spurious tripping.
Fast operation.

Disadvantages:

High cost of installation of private communications.
Metallic paths may transfer high damaging or touch voltages between locations.

5. FAULT THROWER

This is a special application of a fault thrower. It is a form of intertripping using the phase conductors as the medium for communication. The fault thrower would be installed at the source substation and would be operated following opening of the circuit breaker. The device would either put a short circuit on the islanded feeder overloading the circuit and causing operation of generator protection or it could put an earth fault on one phase, causing the operation of generation NVD.

Key features:

Operation would be delayed to allow generator relays to operate if sufficient load imbalance exists. It would only be effective for generators connected between source breaker and first auto recloser. Beyond the recloser, other means such as vector shift would be more appropriate.

Advantages:

With moderate prospective fault currents, it is simple, dependable, reliable and much cheaper than intertripping.

Disadvantages:

More expensive than vector shift and RoCoF.
Introduces operational risks when closing split points.

ANNEX 3- EXPLANATORY NOTES ON NEUTRAL VOLTAGE DISPLACEMENT (NVD) PROTECTION

1.1 General

An NVD scheme measures the displacement of the neutral on the HV side of the generator transformer and operates with delay when the displacement exceeds the trip setting. This device does not detect islanding because an islanding condition can exist without neutral displacement. Its purpose is to detect an earth fault causing an unsafe islanding condition.

Under balanced conditions, the neutral of a 3 phase electrical system is held at the earth potential. This is held by the balanced phase to earth capacitance of the three phase system and the method of earthing of the neutral.

Under earth fault conditions in an unearthed or ineffective earthed network, voltage difference is produced between the system neutral and earth. This displacement of the neutral voltage from the earth voltage is called Neutral Voltage displacement (NVD).

1.2 Derivation of NVD

Consider the general case shown below:

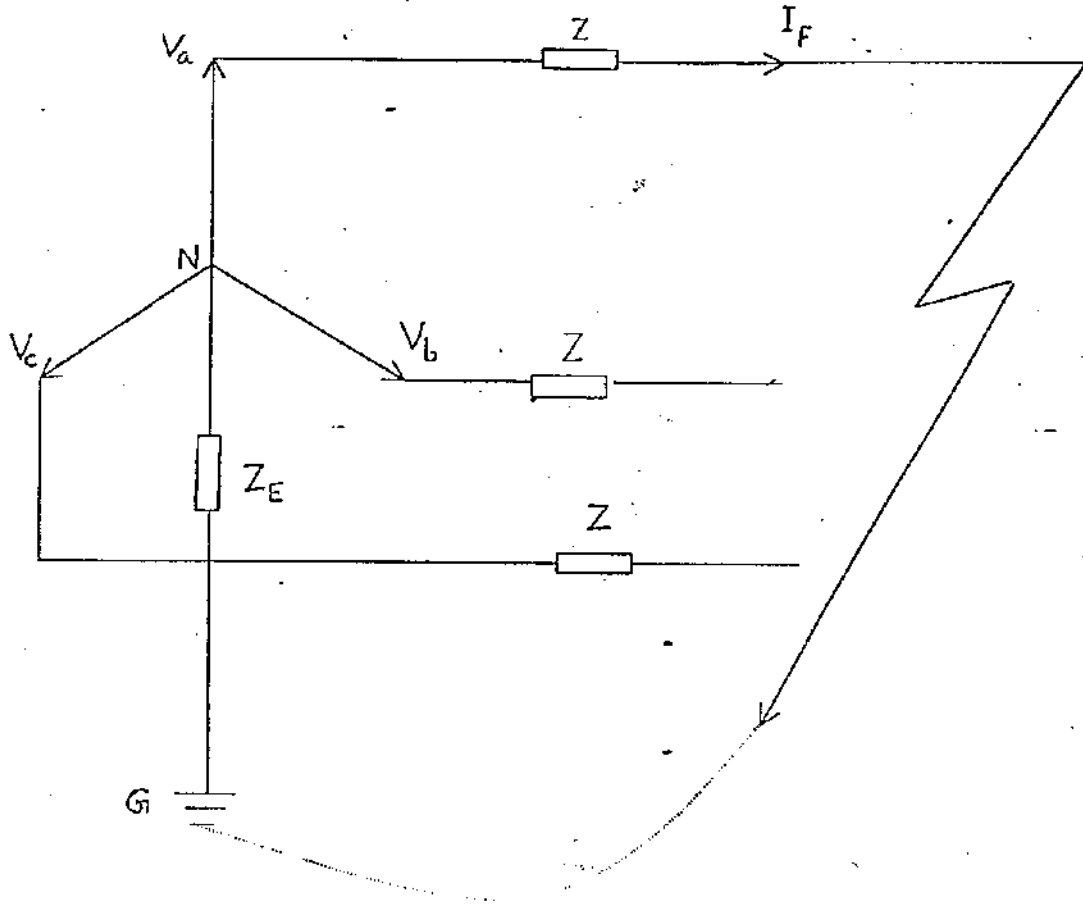

$$I'_{NG} = -I_F Z_E = -I'_{aN} \times \frac{Z_E}{Z_E + Z}$$

$$I'_{aG} = I'_{aN} + I'_{NG}$$

$$I'_{bG} = I'_{bN} + I'_{NG}$$

$$I'_{cG} = I'_{cN} + I'_{NG}$$

$$\therefore I'_{aG} + I'_{bG} + I'_{cG} = 3 I'_{NG} \quad \text{since } I'_{aN} + I'_{bN} + I'_{cN} = 0$$

$$V_{NVi} = \frac{V_{aVi} + V_{bVi} + V_{cVi}}{3} = \frac{3V_n}{3} = V_n$$

V_n = Zero sequence voltage

$V_{aVi} + V_{bVi} + V_{cVi}$ = Sum of the phase to ground voltages and is called the residual voltage

$$I_{RMS} = 3I_n = 3V_{NVi} = 3 \times \text{Neutral Voltage Displacement}$$

1.3 Measurement of NVD

NVD is implemented by having three voltage transformers (VTs) on the HV side of the connection transformer. The VTs are connected phase to ground.

Figure 11 illustrates the connection and operation of NVD protection.

The VTs secondary windings are connected in "broken delta" or "open delta" with an over voltage detection relay connected across the open corner of the delta. This detection relay will then measure the sum of the phase to earth voltages. The VT's must be capable of measuring voltages up to 1.9 pu without the output collapsing.

The NVD could be measured by means of a 3-phase VT having five limbs. The two extra limbs are required to provide return paths for the zero sequence fluxes of the three phases. The primary of the VT is connected in star with the neutral solidly earthed. The secondary windings are connected in series with the two outer terminals brought together, but kept open (open delta). The residual voltage appears across the open delta terminals.

If three single phase VTs are used, then extra limbs are not required as each VT has a closed path for all its sequence magnetic fluxes.

The NVD could also be obtained by measuring the voltage difference between neutral point of a power transformer winding and earth by means of a single phase VT.

1.4 Effects of the Method of Neutral Earthing on NVD

It can be shown by the method of symmetrical components that I_{RMS} during an earth fault mainly depends on the ratio of $\frac{Z_0}{Z_1}$ (K_n) where Z_0 is the zero

sequence impedance in the fault path and Z_1 is the positive sequence impedance. For high impedance earthed or isolated neutrals K_n is very high and I_{RES} will approach 3 times the phase to neutral voltage. For solidly earthed systems, K_n could be small resulting in an insufficient displacement of the neutral voltage.

Under normal operating conditions the sum of the phase to neutral voltages will be near to zero. When there is a ground fault on one of the HV lines there will be a substantial voltage across the detection relay.

The detection relay will then be used to trip either an HV or LV breaker to disconnect the generator from the line.

Key features:

Requires a 5 limb or 3 single phase transformers with open delta connected secondary winding and an earth electrode. HV metering voltage transformers may be utilised to reduce the incremental cost. The voltage transformers must then meet the requirements of metering as well as NVD.

The time delay should be coordinated with the source earth fault protection. Special consideration is required where arc suppression coils are used.

Advantages:

NVD is a dependable means of satisfying safety requirements and mitigating the risk of islanding when generators operate without parallel earthing.

Disadvantages:

NVD does not replace loss of mains and therefore it is an additional cost. It is very expensive if no suitable HV metering voltage transformer is available (i.e. when the point of supply is at LV and HV protection is pole mounted fuses).

Figure 7 - NETWORK VOLTAGES DURING AN EARTH FAULT

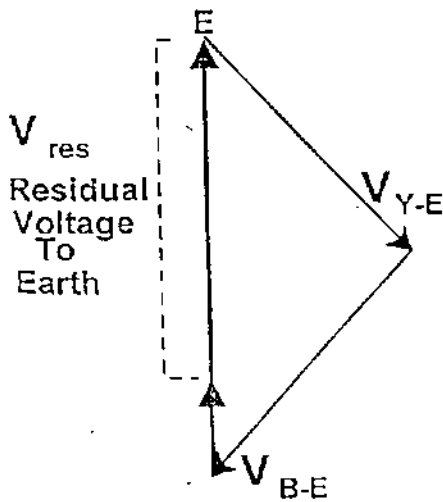
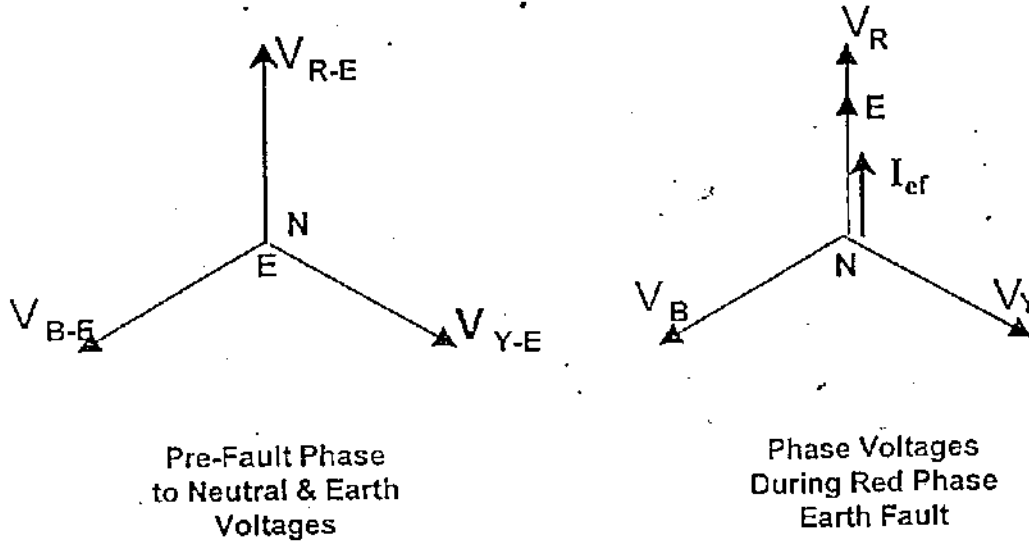

NOTE
 Vectors shown are for an earth fault, assuming a system with a solid earthed neutral and significant earth electrode resistance, or assuming an earth fault in system with a resistance in the neutral to earth connection and a smaller resistive earth impedance. This is a typical condition.

FIGURE 8 - NEUTRAL VOLTAGE DISPLACEMENT PROTECTION USING A THREE PHASE 5 LIMB VOLTAGE TRANSFORMER WITH AN OPEN DELTA WINDING

NOTE

Vectors are shown for an earth fault in a system with an impedance in the neutral to earth connection that is large compared to the source impedance. This is a typical condition.

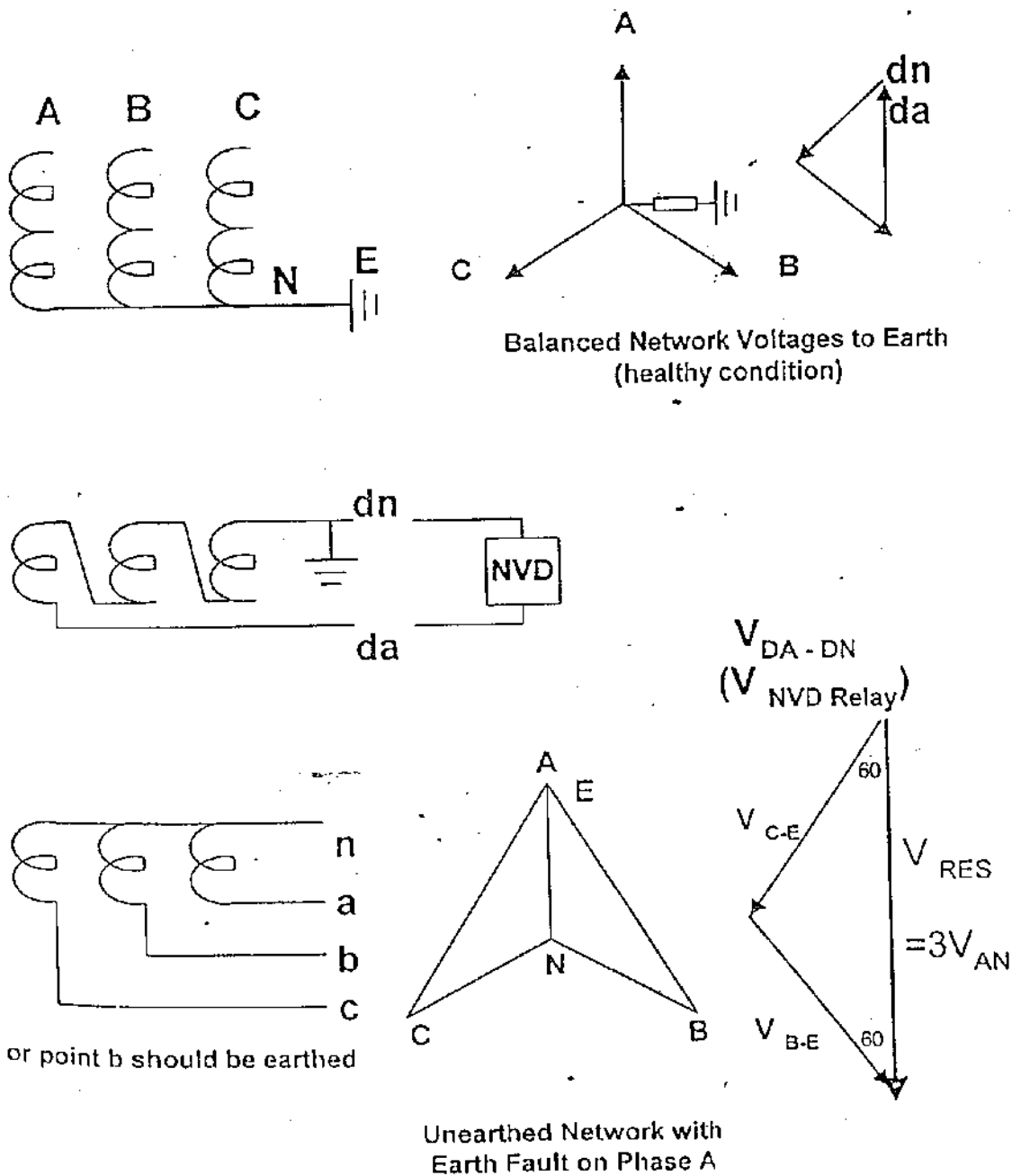

ANNEX 4 – TYPICAL AVR MODELLING INFORMATION

Figure 9 - Example of Typical AVR Modelling

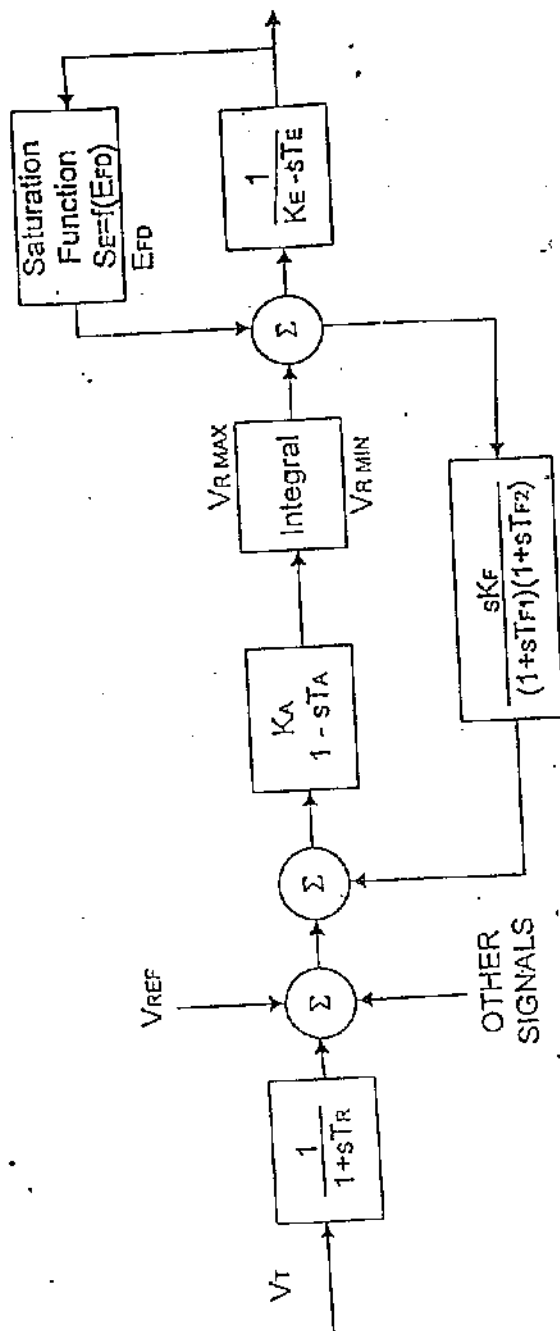

EXCITER GAIN
 TIME CONSTANT
 MAX. OUTPUT P.U.
 MIN. OUTPUT P.U.
 GENERATING UNIT
 TERMINAL VOLTAGE
 MAIN GENERATING
 UNIT FIELD

KE
 Te
 EMAX
 EMIN
 Vt
 EFD

FORWARD GAIN
 FEEDBACK GAIN
 FORWARD TIME CONSTANT
 FEEDBACK TIME CONSTANT
 SECOND FEEDBACK TIME
 CONSTANT
 INPUT FILTER TIME CONSTANT
 AMPLIFIER OUTPUT P.U.
 MAX
 MIN

KA
 Kf
 TA
 Tf1
 Tf2
 Tr
 VR MAX
 VR MIN